

**VILLAGE CENTER COMMUNITY
DEVELOPMENT DISTRICT
POTABLE WATER SYSTEM**

**CROSS-CONNECTION
CONTROL HANDBOOK**

REVISED JANUARY 22, 2025

**OWNER
VILLAGE CENTER COMMUNITY DEVELOPMENT DISTRICT
3571 KIESSEL ROAD
THE VILLAGES, FL 32163
352-750-0000**

**PREPARED BY:
VIKUS WATER
3635 KIESSEL ROAD
THE VILLAGES, FL 32163
352-753-4747**

**VILLAGE CENTER COMMUNITY DEVELOPMENT DISTRICT
POTABLE WATER SYSTEM
CROSS-CONNECTION CONTROL HANDBOOK
JANUARY 2025**

STATEMENT OF POLICY AND LEGAL AUTHORITY3

A. RULES CONCERNING THE PROTECTION OF THE POTABLE WATER SUPPLY SYSTEM5

B. EXCERPTS FROM STATE CODES AND REGULATIONS.....6

C. RESULT OF NON-COMPLIANCE WITH HANDBOOK7

D. HAZARD REVIEW PROCESS AND BFP ASSEMBLY DETERMINATION7

E. INSPECTION10

F. EXISTING FACILITIES10

G. NEW FACILITIES11

H. TESTING AND REPORTING11

I. REPAIRS11

J. EDUCATION PROGRAM12

K. COMPLAINTS AND EMERGENCIES.....13

L. RECORDKEEPING13

M. DEFINITIONS13

APPENDIX A LETTERS AND FORMS17

CROSS-CONNECTION CONTROL PROGRAM LETTER TO COMMERCIAL CUSTOMER18

VCCDD EMERGENCY RESPONSE PROCEDURES IN THE EVENT OF AN IDENTIFIED CROSS-CONNECTION OR BACKFLOW EVENT19

VCCDD WATER SYSTEM CROSS-CONNECTION SURVEY FORM21

VCCDD WATER SYSTEM BACKFLOW PREVENTION ASSEMBLY INSTALLATION RECORD23

TEST AND MAINTENANCE REPORT REQUIREMENTS24

APPENDIX B APPROVED BACKFLOW PREVENTION ASSEMBLIES & INSTALLATION DETAILS25

DOUBLE CHECK VALVE ASSEMBLY26

REDUCED PRESSURE ASSEMBLY37

INSTALLATION DETAILS50

STATEMENT OF POLICY AND LEGAL AUTHORITY

Under the provisions of the Safe Drinking Water Act adopted by the E.P.A. in 1974, the Water Purveyor (supplier) is held responsible for compliance to the provisions of the Act, to include a warranty that water quality provided by his operation is in conformance with the E.P.A. standards at the source, and is delivered to the Customer without the quality being compromised as a result of its delivery through the distribution system.

The safe and efficient operation and maintenance of backflow assemblies is essential in order to properly protect the public from possible hazards caused by contamination. To this end, Village Center Community Development District (VCCDD) endorses the Statement of Policy adopted by the American Water Works Association (AWWA) as follows:

"The American Water Works Association recognizes that the Water Purveyor has a responsibility to provide its Customers at the service connection with water that is safe under all foreseeable circumstances. Thus, in the exercise of this responsibility, the Water Purveyor must take reasonable precautions to protect the community distribution system from the hazards originating on the premises of its Customers that may degrade the water in the community distribution system.

Cross-connection control and plumbing inspections on premises of water Customers are regulatory in nature and should be handled through the rules, regulations and recommendations of the health authority or the plumbing-code enforcement agencies having jurisdiction. The Water Purveyor, however, should be aware of any situation requiring inspection and/or re-inspection necessary to detect hazardous conditions resulting from cross-connections. If, in the opinion of the Utility, effective measures consistent with the degree of hazard have not been taken by the regulatory agency, the Water Purveyor should take such measures as he may deem necessary to ensure that the community distribution system is protected from contamination. Such action would include the installation of a backflow prevention assembly, consistent with the degree of hazard at the service connection or discontinuance of the service.

In addition, Customer use of water from the community distribution system for cooling or other purposes within the Customer's system and later return of the water to the community distribution system is not acceptable and is opposed by AWWA."

VCCDD has adopted this Cross-Connection Control Handbook through adoption of Chapter I and Chapter III of the Rules of the VCCDD. Legal authority for adoption of these Rules is provided via 190.035 F.S., 190.011 (5) F.S., and 120.54 F.S.

In order to implement an effective cross-connection control program, VCCDD adopts the following guidelines:

1. Establish a Cross-Connection Control Handbook outlining policies, rules, regulations, and procedures to be followed to ensure the quality of water supplied by the potable water supply system.
2. Implement an Education Program which may include information provided at the time of request for service, mail-outs to Customers, and newspaper articles.

3. Send personnel who monitor compliance with the program to courses on backflow prevention (BFP) and cross-connection control.
4. Conduct periodic meetings with local plumbing inspection personnel, licensed plumbers and others who will be involved in the installation, inspection, testing and repair of backflow prevention assemblies.
5. Instruct meter readers and maintenance personnel to watch for cross-connections during their daily work schedules and report any cross-connections to management.
6. Establish a policy that specifies the types of service connections that will require a backflow prevention assembly, proper location of the backflow prevention assembly, and a list of all approved assemblies.
7. Ensure that any new construction is reviewed to assess the degree of hazard and ensure that the proper backflow prevention assembly is installed.
8. Continue a backflow protection program to install a residential dual check backflow device at every new residence (existing residential dual check backflow devices are replaced at a minimum of once every ten years).
9. As existing water meters are repaired or replaced at residences, ensure that a residential dual check backflow preventer is set with the new or reworked water meter.
10. Prepare a listing of all testable backflow assemblies in the system and ensure that they are tested by certified test personnel on an annual basis.
11. Maintain records associated with installation, testing, and repair of backflow prevention assemblies.
12. Provide a customer service contact number and specify information handling procedures for complaints and emergencies related to backflow prevention devices and possible cross contamination.

The Cross Connection Control Program Handbook may be amended at any time at the discretion and approval of the District Manager.

A. RULES CONCERNING THE PROTECTION OF THE POTABLE WATER SUPPLY SYSTEM

In order to protect the public water supply system from contamination due to cross-connections, VCCDD hereby establishes the following rules:

- A.1. No installation of potable water supply piping or part thereof shall be made in such a manner that it will be possible for used, unclean, polluted or contaminated water, mixtures or substances to enter any portion of such piping from any tank, receptacle, equipment or plumbing fixture by reason of back-siphonage, back-pressure, or any other cause either during normal use and operation thereof or when any such tank, receptacle, equipment or plumbing fixture is flooded or subject to pressure in excess of the pressure in the hot or cold water piping.
- A.2. No person shall make a connection or allow one to exist between pipes or conduits carrying domestic water supplied by any public or private water service system, and any pipes, conduits or fixtures containing or carrying water from any other source or containing or carrying water which has been used for any purpose whatsoever, or any substances whatsoever, unless there has been provided an approved backflow prevention assembly. The approval of the VCCDD must be obtained before any connection is made between the domestic supply and any contaminated, polluted or auxiliary water system.
- A.3. No plumbing fixture or device shall be installed or maintained or shall be connected to any domestic water supply when such installation or connection may provide a cross-connection between a distributing system of water for drinking and domestic purposes and water which may become contaminated by such plumbing fixture or device unless there has been provided an approved backflow prevention assembly.
- A.4. No water piping supplied by any private water supply system or industrial piping system shall be connected to the potable water system without approval from the VCCDD.
- A.5. Any business, resident, or any other connection having been found by the VCCDD to be a potential backflow source or which meets the established requirements for backflow prevention protection shall install or cause to be installed an approved backflow prevention assembly.
- A.6. All assemblies, which consist of independent units assembled for the purpose of preventing backflow, shall comply with the material, operational, and other specifications of The American Water Works Association (AWWA), The American Society of Sanitary Engineering (ASSE), or the Foundation for Cross-Connection Control and Hydraulic Research (FCCCHR) as required for backflow prevention assemblies. In order to ensure proper operation, all assemblies shall be completely assembled by the manufacturer with all required components. Resilient seated shut-off valves and test cocks are considered to be an integral part of the assembly.

- A.7. The assembled piping shall be thoroughly flushed before installing the backflow prevention assembly.
- A.8. All backflow prevention assemblies shall be adequately supported.
- A.9. All backflow prevention assemblies are the property of the customer. VCCDD shall have no ownership or responsibility for the proper installation, operation, maintenance, or repair of any backflow prevention assembly.

B. EXCERPTS FROM STATE CODES AND REGULATIONS

The following excerpts are herein incorporated into this program by reference, including any future amendments. In the event of any conflict between this Document and other Codes or Regulations, excluding State and Federal Laws, the terms and provisions of this Document shall prevail.

B.1. RULES OF THE STATE OF FLORIDA DEPARTMENT OF ENVIRONMENTAL PROTECTION

SECTION 62-550.200(26):

(26) "CROSS-CONNECTION" means any physical arrangement whereby a public water supply is connected, directly or indirectly, with any other water supply system, sewer, drain, conduit, pool, storage reservoir, plumbing fixture, or other device which contains or may contain contaminated water, sewage or other waste, or liquid of unknown or unsafe quality which may be capable of imparting contamination to the public water supply as the result of backflow. By-pass arrangements, jumper connections, removable sections, swivel or changeable devices, and other temporary or permanent devices through which or because of which backflow could occur are considered to be cross-connections.

SECTION 62-555.360(1), (2), and (3):

(1) Cross-connections, as defined in Rule 62-550.200, F.A.C. are prohibited unless appropriate backflow protection is provided to prevent backflow through the cross-connection into the public water system. This does not prohibit a public water system from being interconnected to another public water system of the same type without backflow protection.

(2) Each community water system (CWS) shall establish and implement a cross-connection control program utilizing backflow protection at or for service connections from the CWS in order to protect the CWS from contamination caused by cross-connections on customers' premises.

(3) Upon discovery of a prohibited or inappropriately protected cross-connection, public water systems either shall ensure that the cross-connection is eliminated, shall ensure that appropriate backflow protection is installed to prevent backflow into the public water system, or shall discontinue water service.

B.2. FLORIDA BUILDING CODE, PLUMBING

CHAPTER 6 – WATER SUPPLY AND DISTRIBUTION:

Section 608 – Protection of Potable Water Supply (Section in its entirety)

608.1 General. A potable water supply system shall be designed, installed and maintained in such a manner so as to prevent contamination from non-potable liquids, solids or gases being introduced into the potable water supply through cross-connections or any other piping connections to the system. Backflow preventer applications shall conform to Table 608.1, except as specifically stated in Sections 608.2 through 608.16.10.

C. **RESULT OF NON-COMPLIANCE WITH HANDBOOK**

Any person or customer failing to comply with this program or part hereof shall be deemed to be in non-compliance, and water service may be terminated by VCCDD until corrective actions required by this program are completed and verified.

C.1. FEES DISCONNECT/RECONNECT:

Fees may be assessed to customers regarding actions taken by VCCDD associated with disconnection/reconnection of service, performance of backflow prevention assembly testing and/or repair, or any other applicable actions. Any person, persons, or customers having been deemed to be in non-compliance with this program shall pay fees as set by VCCDD.

C.2. TERMINATION OF SERVICE:

In emergency conditions, when the public potable water supply is being contaminated or is in danger of contamination, water service may be disconnected by VCCDD.

D. **HAZARD REVIEW PROCESS AND BFP ASSEMBLY DETERMINATION**

D.1. All commercial facilities that intend to connect to the VCCDD water system shall submit a Cross-Connection Control Survey Form at the time of application for water service (see Appendix A).

Failure to comply with the submittal of the Cross-Connection Control Survey form shall be a violation of this program. Upon review, VCCDD shall evaluate the hazard potential and determine the type of backflow prevention assembly that is required. There are varying degrees of hazard, and the degree of protection shall be commensurate with the degree of hazard.

D.2. All commercial connections to the public water system shall be required to have a backflow prevention assembly as otherwise specified herein.

Commencing with the approval of this Handbook by the VCCDD Board of Supervisors, all backflow prevention assemblies that are installed shall be approved by VCCDD or its designated representative.

D.3. **Residential** - All new residential connections will include a residential dual check backflow prevention device that is integral to the meter.

As all existing residential meters are repaired or replaced, water system operations personnel will ensure that a residential dual check backflow prevention device is present or installed. Whenever a residential meter is replaced, the dual check device will be replaced or rebuilt as well.

If any devices or equipment are installed that connect to a residential water line that have the potential for increasing the level of hazard to the public water system, the resident will be responsible for installing an additional backflow prevention assembly in compliance with the requirements of 62-555 F.A.C. and this Handbook. All assemblies shall be installed in accordance with the manufacturer's recommendations. Added backflow prevention assemblies shall be required to be tested and reported in accordance with the requirements of Section H of this Handbook.

If the provisions of this Handbook are not met, VCCDD may disconnect the water service until such time as proper corrections are made and verified.

Fertigation systems, home dialysis machines, or any other equipment or device that presents a high hazard to the potable water system shall require the installation of a reduced pressure backflow assembly. The assembly shall be installed next to the home, upstream of any other connections (i.e., irrigation system).

Residential irrigation systems that are internally connected to the potable water service line shall include the installation of an AVB, PVB, or RP type backflow prevention device. The device shall be installed downstream of the connection to the potable service line and upstream of the valve box and any other irrigation system related connection.

- D.4. **Assembly Location** - Backflow prevention assemblies shall be located on the facility side of the water meter, upstream of any connection points to the water service line. Reduced pressure backflow prevention assemblies shall be located a minimum of 12 inches above finished grade as close to the building as possible so as to allow for screening by landscaping. In no case shall there be any connections to the water service upstream of the backflow prevention assembly.
- D.5. **Assembly Type** - Backflow prevention assembly types shall be as determined by VCCDD or its designated representative. The following chart shows, in general, the types of assemblies that are required as a minimum level of protection for various types of commercial connections. Final determination of the assembly type will be made by VCCDD or its designated representative and will be based on the assessment of the potential hazard to the public water system.

VCCDD COMMERCIAL CONNECTIONS APPROVED BACKFLOW PREVENTION ASSEMBLIES	
Connection Type	Approved BFP Assembly
Restaurant	DCVA
Medical/Dental/Veterinary/Eye Care	RP
Laboratory/Blood Center	RP
Office	DCVA
Grocery Store	RP
Beauty or Nail Salon/Spa	RP
Drug Store	DCVA
Pet Store	DCVA
Convenience Stores	DCVA
Banks/Financial	DCVA
Home Improvement/Hardware	RP
Clothing Retail	DCVA
Furniture Retail	DCVA
Restroom Facility	DCVA
Pool	DCVA with Air Gap
Postal Facility	DCVA
School	DCVA
Church	DCVA
Irrigation (Direct Connection/Commercial)	PVB or RP
Irrigation (Internal Connection/Residential)	AVB, PVB, or RP
Fire Protection System (Without Chemical Additives)	DCVA
Fire Protection System (With Chemical Additives)	RP
Funeral Home	RP
Maintenance Facility (Golf, Landscape, etc.)	RP
Wastewater Pumping Station	RP
Wastewater Treatment Plant	RP
Commercial Car Wash	RP
Assisted Living/Nursing Facility	RP
Independent Living Facility	DCVA
Skilled Nursing Facility	RP
Commercial Laundries/Dry Cleaners	RP
Automotive Repair/Tire Store	RP
Photo Processing Facilities	RP
Pest Control Companies	RP
Cooling Towers	RP
Hospitals	RP
Definitions	
BFP	Backflow Prevention
AVB	Atmospheric-type Vacuum Breaker
DCVA	Double Check Valve Assembly
PVB	Pressure Vacuum Breaker
RP	Reduced Pressure Assembly
Notes	
1. Backflow Prevention Assemblies for facility types not described above shall be submitted to and approved by the District or its authorized representative prior to installation.	
2. An alternate Backflow Prevention Assembly may be submitted for approval. Alternate assemblies shall be approved by the District or its authorized representative prior to installation.	

- D.6. **Approved Assemblies** – Refer to Appendix B for general information on approved backflow prevention assemblies.

Final approval of the specific assembly (manufacturer and model) shall be by VCCDD or their designated representative.

- D.7. Upon completion of the installation of a backflow prevention assembly, the Owner shall submit to VCCDD detailed installation data on the Installation Record form provided in Appendix A as well as an acceptable test report.

E. INSPECTION

- E.1. Duly authorized employees or representatives of VCCDD shall be permitted to enter upon properties for the purpose of sampling or testing the potable water supply, or to make inspections or observations of connections to the potable water supply. Refusal to allow inspection shall constitute a violation of this program.

- E.2. If a backflow prevention assembly is required, the Customer shall have installed the correct backflow prevention assembly as determined by VCCDD. At such time, an inspection by VCCDD will be performed; such inspection by VCCDD shall determine satisfactory compliance by the Customer with this program. If such inspection fails to show compliance with this program, VCCDD shall not be compelled to establish water service until such time that satisfactory compliance has been achieved.

F. EXISTING FACILITIES

- F.1. All premises where cross-connections are suspected shall be surveyed by VCCDD to determine if a detailed inspection will be required. The Owners of the suspected premises shall be contacted to secure an appointment for inspection of the premises. The Owner or his authorized representative will be required to accompany the Inspector during the tour of the premises. A cross-connection survey form will be completed by the Inspector and signed by the Owner or his representative. The Owner shall be made aware of any corrective measures that need to be made. Upon conformance to the requirements in the notification, the Owner shall immediately notify VCCDD to schedule a date for re-inspection.

- F.2. In order for potable water service to be continued, corrective measures identified by VCCDD must be completed by the owner within sixty (60) days or an alternate timeframe as specified by VCCDD.

- F.3. If corrective measures are not completed within the specified timeframe, VCCDD may disconnect water service.

- F.4. If an existing condition is deemed an immediate hazard to the water system, VCCDD may disconnect the water service until such time as corrective measures are completed and verified.

G. NEW FACILITIES

- G.1. All new commercial connections to the VCCDD water system shall require a backflow prevention assembly in accordance with the provisions of this handbook.
- G.2. The presence of a backflow prevention assembly may affect the operation of a facility's fire protection system. Owners should have a registered professional engineer or certified fire-protection system contractor check the hydraulics of the fire protection system to ensure proper operation in conjunction with the presence of the backflow prevention assembly.
- G.3. The installation of thermal expansion devices and/or pressure relief valves is needed within the closed-loop plumbing system created by the required use of backflow prevention assemblies to protect the VCCDD water system.

H. TESTING AND REPORTING

- H.1. Testing shall be required on all backflow prevention assemblies. Testing is to be performed by a certified backflow prevention device technician in accordance with AWWA standards or an individual holding the necessary license. All backflow prevention assemblies, and all devices installed where testing is made possible by the design of the assembly shall be tested a minimum of once every twelve (12) months. In the opinion of VCCDD, if a backflow prevention assembly is used in high hazard applications, it may be required by VCCDD to be tested more frequently.
- H.2. Annual backflow prevention assembly testing and any required maintenance or repair shall be completed and reported to VCCDD by May 1st or September 1st of each year, depending on the due date that has been assigned to a location. An alternate schedule or greater frequency may be approved/required by VCCDD.
- H.3. Customers may receive a past due notice from VCCDD if an annual passing test report is not received in accordance with the dates indicated by VCCDD.
- H.4. If an acceptable test report that includes all of the required information, as shown in Appendix A, titled "VCCDD Water System Backflow Prevention Assembly Test and Maintenance Report Requirements" is not received in accordance with the required timeframes, VCCDD, at its option, may perform any required maintenance, repair, or installation, as applicable, and then have the test conducted. All costs incurred by VCCDD, as provided for by Rule, will be included on the customer's utility bill.

I. REPAIRS

- I.1. A backflow prevention assembly that fails a test or does not meet the standards of this program is required to be repaired/replaced by the Owner to correct any deficiencies or problems with the assembly.

The Customer, Owner or Authorized Agent for the Owner shall be responsible for any and all repairs/replacement necessary to maintain good working condition of the backflow prevention assembly. Repairs shall be performed by a certified backflow prevention device repair technician or an individual holding the necessary license.

- I.2. Certified backflow prevention device repair technician or an individual holding the necessary license shall determine and affirm to VCCDD satisfactory repair and compliance of the backflow prevention equipment. Said affirmation of compliance by the technician shall be provided to VCCDD in accordance with the schedule in Section H, Testing and Reporting.

J. EDUCATION PROGRAM

- J.1. Upon application for water service, all potential commercial customers will receive a copy of a letter titled "Cross-Connection Control Program." This letter explains the responsibilities of VCCDD and the commercial customer regarding our Cross-Connection Control Program. The letter also includes instructions for downloading a copy of the Cross-Connection Control Handbook. A copy of the letter can be found in Appendix A.
- J.2. Commercial customers will receive an annual letter by mail prior to their backflow assembly test due date as a reminder of the reporting requirements and that their annual backflow assembly test is due. If an acceptable backflow assembly test report is not received within the specified time, a past due letter will be mailed to the customer advising them of their non-compliance. If after receiving a past due letter an acceptable backflow assembly test report is not received within the specified time, further steps will be taken by VCCDD as explained in Section H, Testing and Reporting. It is the responsibility of the customer to ensure that an acceptable backflow assembly test report is submitted for each backflow assembly that exists at their location.
- J.3. Residential irrigation and landscaping contractors who are working within The Villages® community may obtain a copy of the VCCDD Cross-Connection Control Handbook via the website at www.districtgov.org.
- J.4. Periodic newspaper articles will be in the local newspaper to notify residential and commercial customers of the backflow prevention and water system protection issues.
- J.5. Meter readers and utility operations personnel will receive training regarding the requirements for commercial and residential backflow prevention assemblies. Locations that are found to be non-compliant with the provisions of this handbook will receive individual notification of actions that must be taken to bring the connection into compliance.

K. COMPLAINTS AND EMERGENCIES

- K.1. **Normal Business Hours-** Complaints and emergencies regarding backflow issues shall be directed to the VCCDD utility customer service number (352) 750-0000 from 8:00AM to 5:00PM, Monday through Friday.
- K.2. **After Hours and on Weekends-** Complaints and emergencies regarding backflow issues shall be directed to Community Watch (352) 753-0550.
- K.3. Information regarding backflow complaints and emergencies will be relayed to utility operations personnel who will implement required response actions. Utility operations personnel are on call twenty-four (24) hours per day, seven (7) days per week.
- K.4. In the event of an identified cross-connection or backflow occurrence the VCCDD utility response procedures can be found in Appendix A.

L. RECORDKEEPING

- L.1. All records will be maintained for not less than ten (10) years.
- L.2. Records will be maintained by the VCCDD Utility Department or their designated representative.
- L.3. Records will be kept on items including, but not limited to:
 - a) Cross-Connection Survey Forms
 - b) Backflow Prevention Assembly-Installation Records
 - c) Backflow Prevention Assembly-Test and Maintenance Reports
 - d) Backflow Complaint and Emergency Work Orders
 - e) Education Program Materials

M. DEFINITIONS

AIR GAP: A physical separation between the free-flowing discharge end of a potable water supply pipeline and an open or non-pressure receiving vessel. An "approved air-gap separation" shall be at least double the diameter of the supply pipe measured vertically above the top of the rim of the vessel. In no case shall it be less than 1 inch.

APPROVED: 1) The term "approved" as herein used in reference to a water supply shall mean a public water supply that has been approved by the Florida Department of Environmental Protection or the delegated county health department in which the water supply is located. 2) The term "approved" as herein used in reference to an air gap, a double check valve assembly, a reduced pressure backflow prevention assembly or other backflow prevention assemblies or methods shall mean approved per Chapter 62-555.360, FAC.

ATMOSPHERIC-TYPE VACUUM BREAKER: A backflow prevention device which is operated by atmospheric pressure in combination with the force of gravity. The unit is designed to work on a vertical plane only and does not possess any test cocks or shut-off valves.

AUXILIARY WATER SUPPLY: Any water supply on or available to the premises other than VCCDD approved potable water supply. These auxiliary waters may include water from another purveyor's potable water supply or any natural source(s) such as a well, spring, stream, river, harbor, etc., or "used waters" or "industrial fluids". These waters may be objectionable and constitute an unacceptable water source over which the water purveyor does not have sanitary control.

BACK PRESSURE: Any elevation of pressure in the downstream piping system (by pump, elevation of piping, or steam and/or air pressure) above the supply pressure at the point of consideration which would cause - or tend to cause - a reversal of the normal direction of flow through the backflow prevention assembly.

BACK-SIPHONAGE: A form of backflow due to a reduction in system pressure which causes a negative or sub-atmospheric pressure to exist at a site in the water system.

BACKFLOW: The undesirable reversal of flow of water or mixtures of water and other liquids, gases or other substances into the distribution pipes of the potable supply of water from any source or sources.

BACKFLOW PREVENTION ASSEMBLY: A device or means designed to prevent back-pressure, back-siphonage, or backflow.

CONTAMINATION: An impairment of the quality of the potable water by sewage, industrial fluids or waste liquids, compounds or other materials to a degree which creates an actual hazard to the public health through poisoning or through the spread of disease (see also pollution).

CROSS-CONNECTION: Any physical arrangement whereby a potable water supply is connected, directly or indirectly, with any other water supply system, sewer, drain, conduit, pool, storage reservoir, plumbing fixture, or other device which contains or may contain contaminated water, sewage or other waste or liquid of unknown or unsafe quality which may be capable of imparting contamination to the potable water supply as the result of backflow. Bypass arrangements, jumper connections, removable sections, swivel or changeable devices and other temporary or permanent devices through which or because of which backflow could occur are considered to be cross-connections.

CROSS-CONNECTION, CONTROLLED: A connection between a potable water system and a non-potable water system with an approved backflow prevention assembly properly installed that will continuously afford protection against contamination or pollution commensurate with the degree of hazard.

CROSS-CONNECTION CONTROL BY CONTAINMENT: The installation of an approved backflow prevention assembly at the service connection to any Customer's premises where it is not physically and economically feasible to find and permanently eliminate or control all actual or potential cross-connections within the Customer's water system; or it shall mean the installation of an approved backflow prevention assembly on the service line leading to and supplying a portion of a Customer's water system where there are actual or potential cross-connections which cannot be effectively eliminated or controlled at the point of connection.

DOUBLE CHECK VALVE ASSEMBLY: An assembly composed of two single, independently acting, check valves, including tightly closing shutoff valves located at each end of the assembly and suitable connections for testing the water tightness of each check valve. A check valve is a valve that is drip-tight in the normal direction of flow when the inlet pressure is 1 psi and the outlet pressure is zero. The check valve shall permit no leakage in a direction reverse to the normal flow. The closure element (e.g., clapper) shall be internally weighted or otherwise internally loaded to promote rapid and positive closure.

DUAL CHECK VALVE ASSEMBLY: An assembly of two (2) spring loaded, independently operating check valves without tightly closing shut-off valves and test cocks, generally employed immediately downstream of the water meter to act as a containment device.

HAZARD, DEGREE OF: A measure of hazard derived from an evaluation of the potential risk to public health and the adverse effect of the hazard upon the potable water system.

HAZARD, HEALTH: Any condition, device or practice in the water supply system and its operation which could create, or in the judgment of VCCDD, may create a danger to the health and well-being of the water Consumer. An example of a health hazard is a structural defect, including cross-connections, in a water supply system.

HAZARD, PLUMBING: A plumbing type cross-connection in a Consumer's potable water system that has not been properly protected by a vacuum breaker, air-gap separation, or backflow prevention assembly. Unprotected plumbing type cross-connections are considered to be a health hazard.

HAZARD, POLLUTION: An actual or potential threat to the physical properties of the water system or to the potability of the Public or the Consumer's potable water system, but which would constitute a nuisance or be aesthetically objectionable or could cause damage to the system or its appurtenances, but would not be dangerous to health.

HAZARD, SYSTEM: An actual or potential threat of severe danger to the physical properties of the potable water system or the Consumer's potable water system or of a pollution or contamination which would have a protracted effect on the quality of the potable water in the system.

INDUSTRIAL FLUIDS SYSTEM: Any system containing fluid or solution which may be chemically, biologically or otherwise contaminated or polluted in a form or concentration such as would constitute a health, plumbing, pollution or system hazard if introduced into the public potable water supply.

This may include, but not be limited to: polluted or contaminated waters; all types of process waters and "used waters" originating from the public potable water system which may have deteriorated in sanitary quality; chemicals in fluid form; plating acids and alkalis, circulated cooling waters connected to an open cooling tower and/or cooling towers that are chemically or biologically treated or stabilized with toxic substances; contaminated natural water such as from wells, springs, streams, rivers, bays, harbors, seas, irrigation canals or systems, etc.; oils, gases, glycerine, paraffins, caustic and acid solutions and other liquids and gaseous fluids used for industrial or other purposes or for fire-fighting purposes.

POLLUTION: The presence of any foreign substance (organic, inorganic, or biological) in water which tends to degrade its quality so as to constitute a hazard or impair the usefulness or quality of the water to a degree which does not create an actual hazard to the public health but which does adversely and unreasonably affect such waters for domestic use.

REDUCED PRESSURE BACKFLOW PREVENTION ASSEMBLY: A device containing within its structure a minimum of two (2) independently acting approved check valves, together with an automatically operating pressure differential relief valve located between the two check valves.

The first check valve reduces the supply pressure a predetermined amount so that during normal flow and at cessation of normal flow the pressure between the checks shall be less than the supply pressure. In case of leakage of either check valve, the differential relief valve, by discharging to atmosphere, shall operate to maintain the pressure between the checks less than the supply pressure. The unit shall include tightly closing shutoff valves located at each end of the device, and each device shall be fitted with properly located test cocks.

WATER, NON-POTABLE: Water which is not safe for human consumption.

WATER, POTABLE: Any water which, according to recognized Standards, is safe for human consumption.

WATER PURVEYOR: The Owner or Operator of a Potable Water Utility supplying a potable water supply to the Public.

WATER SERVICE CONNECTIONS: The terminal end of a service connection from the potable water system; i.e., where VCCDD loses sanitary control over the water at its point of delivery to the Customer's water system. If a meter is installed at the end of the service connection, then the service connection shall mean the downstream side of the meter. There should be no unprotected takeoffs from the service line ahead of any meter or backflow prevention assembly located at the point of delivery to the Customer's water system. Service connections shall also include water service connections from a fire hydrant and all other temporary or emergency water service connections from the public potable water system.

WATER - USED: Any water supplied by a Water Purveyor from a potable water system to a Consumer's water system after it has passed through the point of delivery and is no longer under sanitary control of the Water Purveyor.

APPENDIX A

LETTERS AND FORMS

CROSS-CONNECTION CONTROL PROGRAM **LETTER TO COMMERCIAL CUSTOMER**

Dear Utility Customer,

The Potable water supplied to your facility is provided by a water system owned by Village Center Community Development District (VCCDD). VCCDD is responsible for the operation and maintenance of the public water supply beginning at the source and ending at the point of delivery to the customer. A critical element to operating a potable water system is to ensure the protection of the health and safety of the water supplied. One of the ways that this is achieved is by requiring that a Backflow Prevention Assembly be installed at all service connections. A Backflow Prevention Assembly is typically either a Double Check (DC) or Reduced Pressure Assembly (RP) and is located on the customer side of the water meter. Backflow Prevention Assemblies are installed on water service lines to all commercial buildings, irrigation, and fire line services. This is further explained in the Cross-Connection Control Program Handbook that was created by VCCDD in compliance with the rules of the Florida Department of Environmental Protection (FDEP). The Cross-Connection Control Program Handbook outlines the requirements of the customer, which includes installation and annual testing and maintenance on all Backflow Prevention Assemblies. A copy of the Cross-Connection Control Handbook can be downloaded on our website at www.DistrictGov.org by selecting the following: Departments - Utilities - Commercial Customers - and then under the heading Cross-Connection Control Handbook, select VCCDD - Download Here.

COMMONLY ASKED QUESTIONS REGARDING CROSS-CONNECTION AND BACKFLOW

What is a cross-connection?

A cross-connection is a point in a plumbing system where the potable water supply is connected to a non-potable source.

Where might cross-connections be found?

They can be found in all plumbing systems in areas such as:

- Wash Basins and Service Sinks
- Irrigation sprinkler Systems
- Medical and Dental Equipment
- Hose Bibs
- Photo Developing Equipment
- Fire Sprinkler Systems

What is backflow?

It is the unwanted flow of non-potable or contaminated fluids back into the customer's plumbing system and/or the public water system. There are two types of backflow, see below:

- Backsiphonage- caused by a negative pressure in the supply line to a facility or plumbing fixture.
- Backpressure- can occur when the potable water supply is connected to another system operated at a higher pressure or has the ability to create pressure. Primary causes are booster pumps, pressure vessels, elevated plumbing, etc.

What is a cross-connection control program?

It is a program required by the FDEP to detect and prevent possible sources of non-potable water or contaminants from entering the public water supply.

Why do backflow assemblies need to be tested every year?

The backflow assembly is a mechanical device that needs maintenance just as a vehicle does. The annual test indicates if the internal check valves and mechanics are working properly. Annual testing and maintenance, if necessary, is also required by FDEP and VCCDD.

**VCCDD EMERGENCY RESPONSE PROCEDURES IN THE EVENT OF AN IDENTIFIED
CROSS-CONNECTION OR BACKFLOW EVENT**

The following Procedures will be followed by VCCDD personnel in the event of an identified water system cross-connection or backflow event.

1. DISCONNECT

- Eliminate the cross-connection or disconnect the backflow source.

3. REPORT

- Immediately report the incident to the following utility contacts:

CONTACT	PHONE NUMBER
VCCDD Administrative Operations Manager	(352) 751-3939
Jacobs Project Director	(352) 259-2802
VCCDD Utility Engineer	(352) 753-4747
Jacobs Project Manager	(352) 303-1256
VCCDD Public Safety	(352) 205-8280
After Hours or Weekends - Community Watch	(352) 753-0550

- Begin documentation log at notification of cross-connection to include date, time, location, and activities associated with the event.

3. INVESTIGATION/NOTIFICATION

- Perform an investigation of the cross-connection to identify the potential contaminant and the degree of hazard.
- Do an assessment to determine the potential impact area.
- If a known contaminant has been introduced into the water system, isolate the impacted area and shut down the water system.
- Notify all affected homes and businesses regarding the system outage.
- If it cannot be determined that a contaminant has been introduced into the water system, issue a Boil Water Notice to the potentially impacted area using the following procedures:
 - Send email to the VCCDD Utilities email group identifying the incident that occurred, location of incident, and number of homes/businesses affected.
 - Provide a PSA for the billing and Customer Service Division, VCCDD Utilities email group, and the Public Safety Department.
 - Place door hangers on the front door of homes that are affected by the incident and directly contact affected businesses.
- Notify the Florida Department of Environmental Protection.
- Notify the County Health Departments at the following numbers:

HEALTH DEPARTMENT	PHONE NUMBERS
Sumter County Health Department	(352)793-7133
Marion County Health Department	(352) 629-0137
Lake County Health Department	(352) 589-6424

4. CORRECTION

- Implement technical activities to repair and correct the cross-connection or backflow event.
- Flush and decontaminate the water system as necessary.
- Perform a site inspection of the affected area to be sure the cross-connection source has been eliminated.
- Perform water samples to be sure the distribution system is free of any contaminants

5. RESCIND NOTIFICATION

- Notify the VCCDD Utilities email group and the affected homes when the precautionary boil water notice is rescinded by placing door hangers on the front door of the homes that were affected. Businesses should be contacted directly.

VCCDD WATER SYSTEM
CROSS-CONNECTION SURVEY FORM

ACCOUNT NUMBER: _____
DATE COMPLETED: _____
FACILITY NAME: _____
CONTACT NAME: _____
FACILITY ADDRESS: _____
FACILITY PHONE: () _____ FACILITY FAX: () _____
OWNER NAME: _____
CONTACT NAME: _____
OWNER ADDRESS: _____
OWNER PHONE: () _____ OWNER FAX: () _____
TYPE OF FACILITY: _____
DESCRIBE ACTIVITIES AT THE FACILITY: _____

WATER SERVICE LINE SIZE (in): _____ WATER METER SIZE (in): _____

NOTE: Completion of this form is required prior to initiation of water service

<u>QUESTIONS</u>	<u>YES</u>	<u>NO</u>
1. Is there another source of water to the property other than the service connection to the public potable supply i.e., a private well, lake, stream, river, pond, etc.?	()	()
2. Is there an irrigation system on the property?	()	()
3. Are there any facilities (such as a booster pump, pressure tank, etc.) that increase the water pressure to the facility or any portion thereof, above the supply pressure presently provided by the potable supply?	()	()
4. Are any chemicals used in the operation?	()	()
5. Are any chemicals stored at the facility?	()	()
6. Are any ejectors, aspirators, or pumps used in the operation?	()	()
7. Is any water recycled during the operation of an air conditioner or other equipment in your plant or building?	()	()
8. Are there any water supply lines submerged in tanks, vats, etc.?	()	()
9. Is there a fire stand-pipe or fire sprinkler system installed in the building?	()	()

PROVIDE APPROPRIATE DETAILS ON ALL QUESTIONS ANSWERED "YES".

ATTACH ADDITIONAL SHEETS AS NECESSARY:

Acknowledgement: Details regarding the Cross-Connection Control Program are contained in a handbook that has been adopted by VCCDD. By my signature below, I acknowledge that VCCDD has made the Cross-Connection Control Program Handbook available to me by logging on to www.DistrictGov.org and then selecting the following: Departments - Utilities - Commercial Customers - and then under the heading Cross-Connection Control Handbook, select VCCDD - Download Here. I further agree to be bound by the conditions and guidelines included therein. I also acknowledge that the information that I have provided is correct to the best of my knowledge and may result in the requirement of additional actions. Such actions may include, but are not limited to, installation of or modification of a backflow prevention assembly. Any action, if required, will be the responsibility of the customer or facility owner, as appropriate. Actions shall be completed within 30 days of receipt of notification by VCCDD or its designated agent.

OWNER OR AGENT: _____ TITLE: _____
(Please Print)

SIGNATURE: _____ DATE: _____

VCCDD
REPRESENTATIVE: _____ DATE: _____

Upon completion of this form, please return the original to:

Village Center Community Development District
Attention: Cross-Connection Control Program
3635 Kiessel Road
The Villages, FL 32163
Renee.Smith@VikusWater.com
Fax: (352) 753-1296

VCCDD WATER SYSTEM
BACKFLOW PREVENTION ASSEMBLY INSTALLATION RECORD

ACCOUNT NUMBER: _____
DATE COMPLETED: _____
FACILITY NAME: _____
OWNER: _____
OWNER ADDRESS: _____
OWNER PHONE: () _____ OWNER FAX: () _____
FACILITY ADDRESS / LOCATION: _____
FACILITY PHONE: () _____ FACILITY FAX: () _____

LOCATION 1

WATER SERVICE DESCRIPTION (potable indoor, irrigation, pool make-up, etc.)

WATER SERVICE LINE SIZE (in): _____ WATER METER SIZE (in): _____

BACKFLOW PREVENTION ASSEMBLY:

Manufacturer: _____
Model Number: _____
Size (in): _____
Type (Double Check, Reduced Pressure Assembly, etc): _____

LOCATION 2

WATER SERVICE DESCRIPTION (potable indoor, irrigation, pool make-up, etc.)

WATER SERVICE LINE SIZE (in): _____ WATER METER SIZE (in): _____

BACKFLOW PREVENTION ASSEMBLY:

Manufacturer: _____
Model Number: _____
Size (in): _____
Type (Double Check, Reduced Pressure Assembly, etc): _____

Please attach additional sheets as necessary for additional water system service connections.

Completed forms shall be submitted to:

Village Center Community Development District
Attention: Backflow Prevention Program
3635 Kiessel Road
The Villages, FL 32163
Renee.Smith@VikusWater.com
Fax: (352) 753-1296

VCCDD WATER SYSTEM
BACKFLOW PREVENTION ASSEMBLY
TEST AND MAINTENANCE REPORT REQUIREMENTS

The following information should be included on the backflow test report form provided by the backflow assembly tester. The test report form should also include all the necessary assembly testing results and requirements.

Facility and Owner Information

- Date of Test
- Facility Account Number
- Facility Name
- Facility Address
- Facility Phone Number
- Owner Name
- Owner Address
- Owner Phone Number

Assembly Description

- Location of Assembly
- Manufacturer, Model Number, and Serial Number
- Type of Assembly (Double Check, Reduced Pressure Assembly, etc.)
- Size of Assembly

Meter Information

- Meter Size
- Meter Type (potable, irrigation, fire)
- Serial Number

Tester Information

- Company Name
- Phone Number
- Tester Name (**clearly written or typed**)
- Tester Certification Number
- Gauge Manufacturer, Model Number, and Serial Number
- Current Calibration Date of Gauge

All forms shall be completed and submitted to:

Village Center Community Development District
Attention: Backflow Prevention Program
3635 Kiessel Road
The Villages, FL 32163
Renee.Smith@VikusWater.com
Fax: (352) 753-1296

**APPENDIX B
APPROVED BACKFLOW PREVENTION ASSEMBLIES
& INSTALLATION DETAILS**

DOUBLE CHECK VALVE ASSEMBLY



Series LF2000B

Double Check Valve Assemblies

Sizes: 1/2" – 2" (15 – 60mm)

LEAD FREE*

Features

- Ease of maintenance with only one cover
- Top entry
- Replaceable seats and seat discs
- Modular construction
- Compact design
- 1/2" – 2" (15 – 50mm) Lead Free* cast silicon copper alloy body construction
- Top mounted ball valve test cocks
- Low pressure drop
- No special tools required
- 1/2" – 1" (15 – 25 mm) have tee handles



3/4" LF2000B
(20mm)

Series LF2000B Double Check Valve Assemblies shall be installed at referenced cross-connections to prevent the backflow of polluted water into the potable water supply. Only those cross-connections identified by local inspection authorities as non-health hazard shall be allowed the use of an approved double check valve assembly.

Check with local authority having jurisdiction regarding vertical orientation, frequency of testing or other installation requirements.

These valves meet the requirements of ASSE Std. 1015 and AWWA Std. C510 and are approved by the Foundation for Cross-Connection Control and Hydraulic Research at the University of Southern California. The LF2000B features Lead Free* construction to comply with Lead Free* installation requirements.

Available Models

Suffix:

B - Quarter turn ball valves

LBV - less ball valves

Pressure — Temperature

Temperature Range: 33°F – 140°F
(0.5°C – 60°C)

Maximum Working Pressure: 175psi
(12.06 bar)

Specifications

A Double Check Valve Assembly shall be installed at each noted location. The Double Check Valve Assemblies shall be constructed using Lead Free* materials. Lead Free* valves shall comply with state codes and standards, where applicable, requiring reduced lead content. The assembly shall consist of two positive seating check modules with captured springs and rubber seat discs. The check module seats and seat discs shall be replaceable. Service of all internal components shall be through a single access cover secured with stainless steel bolts. The assembly shall also include two resilient seated isolation valves and four top mounted, resilient seated test cocks. The assembly shall meet the requirements of ASSE Std. 1015 and AWWA Std. C510. Approved by the Foundation for Cross-Connection Control and Hydraulic Research at the University of Southern California. Assembly shall be an Ames Company Series LF2000B.

Standards

AWWA Std. C510, IAPMO PS31

*The wetted surface of this product contacted by consumable water contains less than 0.25% of lead by weight.

Approvals



Approved by the Foundation for Cross-Connection Control and Hydraulic Research at the University of Southern California.

LBV models not listed.

Horizontal and vertical "flow up" approval on all sizes.

Job Name _____ Contractor _____

Job Location _____ Approval _____

Engineer _____ Contractor's P.O. No. _____

Approval _____ Representative _____

Ames product specifications in U.S. customary units and metric are approximate and are provided for reference only. For precise measurements, please contact Ames Technical Service. Ames reserves the right to change or modify product design, construction, specifications, or materials without prior notice and without incurring any obligation to make such changes and modifications on Ames products previously or subsequently sold.

Dimensions – Weights

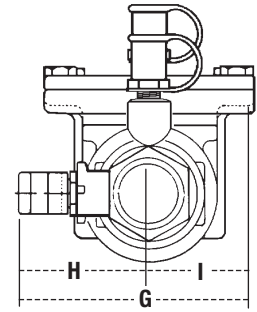
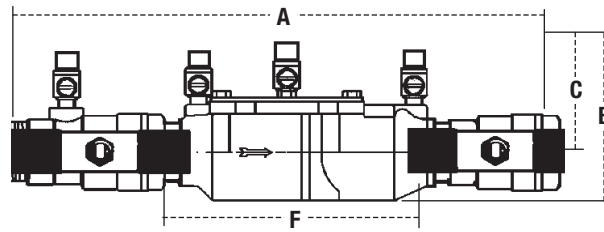

LF2000B

SIZE (DN)		DIMENSIONS										WEIGHT					
in.	mm	A		B		C		F		G		H		I		lbs.	kgs.
		in.	mm	in.	mm	in.	mm	in.	mm	in.	mm	in.	mm	in.	mm		
1/2	15	10	254	4 1/8	117	2 1/16	62	5	127	3 3/8	85	2 9/16	59	2 1/16	52	4.5	2
3/4	20	11 1/8	282	4	102	3 1/8	79	6 3/16	157	3 1/16	87	2 1/8	54	1 1/16	33	5	2.3
1	25	13 3/4	337	5 1/8	130	4	102	7 1/2	191	3 3/8	85	11 1/16	43	11 1/16	43	12	5.4
1 1/4	32	16 3/4	416	5	127	3 3/16	84	9 1/2	241	5	127	3	76	2	50	15	6.8
1 1/2	40	16 3/4	425	4 7/8	124	3 1/2	89	9 3/4	248	5 1/16	148	3 1/8	79	2 1/16	68	15.86	7.2
2	50	19 1/2	495	6 1/4	159	4	102	13 3/8	340	6 1/8	156	3 7/16	87	2 1/16	68	25.75	11.7

Strainer sold separately

Capacities

As compiled from documented Foundation for Cross-Connection Control and Hydraulic Research at the University of Southern California lab tests.
*Typical maximum system flow rate (7.5 feet/sec., 2.3 meters/sec.)

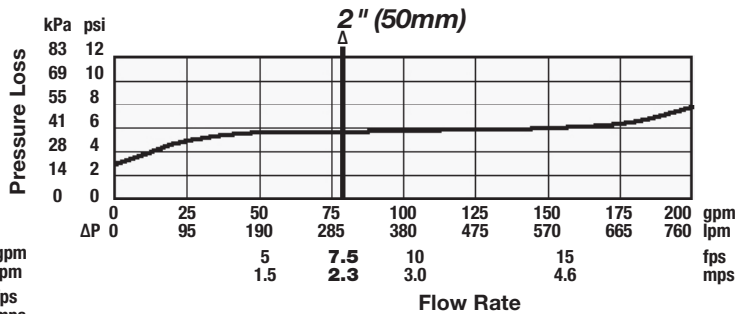
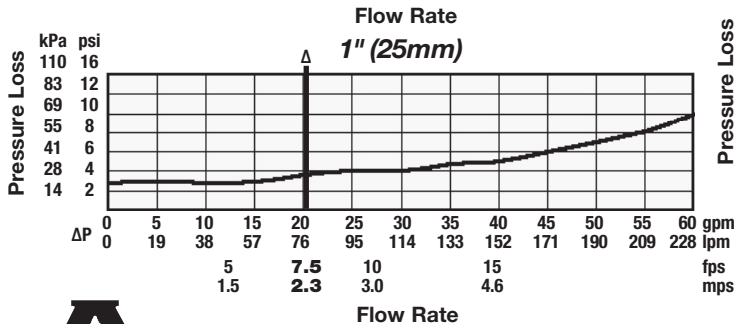
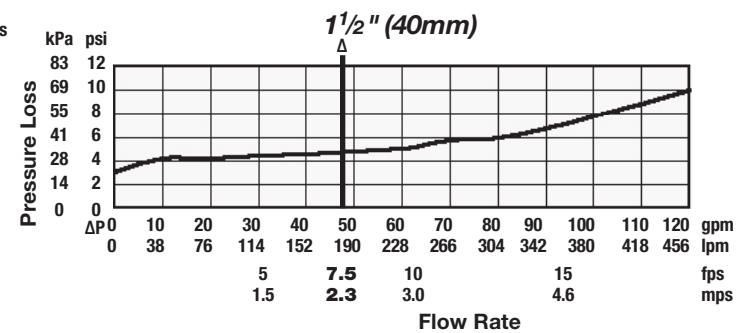
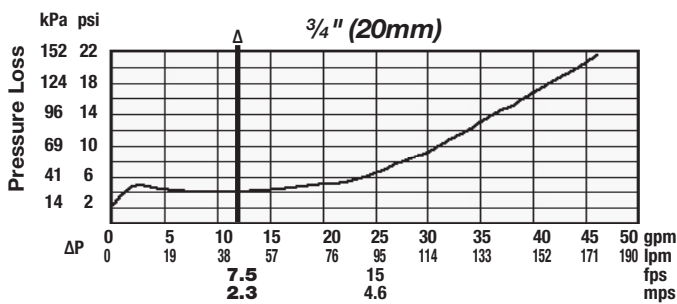
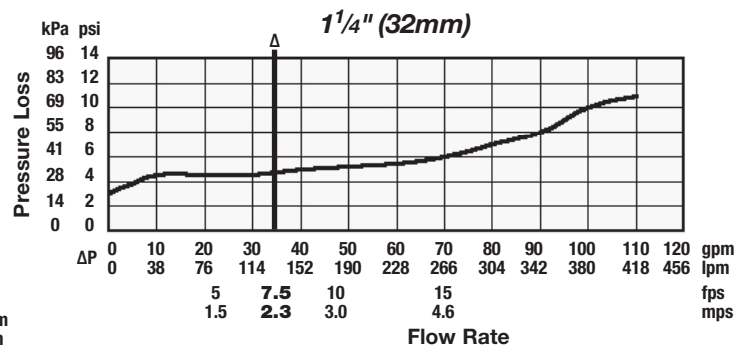
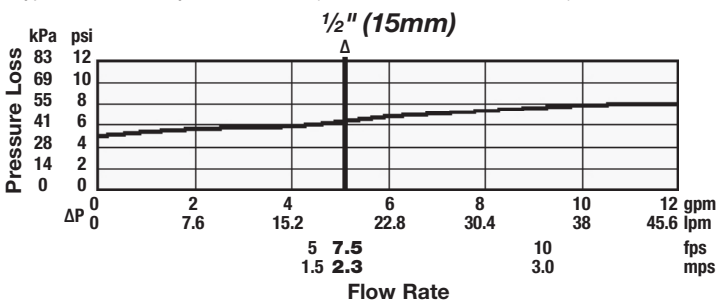

www.amesfirewater.com



ISO 9001-2008
CERTIFIED

A Watts Water Technologies Company

USA: Backflow- Tel: (916) 928-0123 • Fax: (916) 928-9333
Control Valves- Tel: (713) 943-0688 • Fax: (713) 944-9445
Canada: Tel: (905) 332-4090 • Fax: (905) 332-7068

Job Name _____

Contractor _____

Job Location _____

Approval _____

Engineer _____

Contractor's P.O. No. _____

Approval _____

Representative _____

LEAD FREE*

Series 2000SS Double Check Valve Assemblies

Sizes: 2½" – 12" (65 – 300mm)

Features

- Cam-Check Assembly provides low head loss
- Short lay length is ideally suited for retrofit installations
- Stainless Steel body is half the weight of competitive designs reducing installation and shipping cost
- Stainless steel construction provides long term corrosion protection and maximum strength
- Single top access cover with two-bolt grooved style coupling for ease of maintenance
- No special tools required for servicing
- Compact construction allows for smaller vaults and enclosures
- May be installed in horizontal or vertical "flow up" position (ASSE Only)

Available Models

Suffix:

- NRS** – non-rising stem resilient seated gate valves
- OSY** – UL/FM outside stem and yoke resilient seated gate valves
- **OSY FxG** – flanged inlet gate connection and grooved outlet gate connection
- **OSY GxF** – grooved inlet gate connection and flanged outlet gate connection
- **OSY GxG** – grooved inlet gate connection and grooved outlet gate connection
- LG** – less gates

Available with grooved NRS gate valves – consult factory**

Post indicator plate and operating nut available – consult factory**

**Consult factory for dimensions

NOTICE

Inquire with governing authorities for local installation requirements

***The wetted surface of this product contacted by consumable water contains less than 0.25% of lead by weight.**

Ames Fire & Waterworks product specifications in U.S. customary units and metric are approximate and are provided for reference only. For precise measurements, please contact Ames Fire & Waterworks Technical Service. Ames Fire & Waterworks reserves the right to change or modify product design, construction, specifications, or materials without prior notice and without incurring any obligation to make such changes and modifications on Ames Fire & Waterworks products previously or subsequently sold.



2000SS

Series 2000SS Double Check Valve Assemblies are designed to prevent the reverse flow of polluted water from entering into the potable water system. This series can be applied, where approved by the local authority having jurisdiction, on non-health hazard installations. Features short end-to-end dimensions, lightweight stainless steel body, and low head loss.

Specifications

A Double Check Valve Assembly shall be installed at each noted location to prevent the unwanted reversal of polluted water into the potable water supply. The main valve body shall be manufactured from 300 series stainless steel to provide corrosion resistance, 100% lead free through the waterway. The double check shall consist of two independently operated spring loaded cam-check valves, required test cocks, and optional inlet and outlet resilient seated shutoff valves. Each cam-check shall be internally loaded and provide a positive drip tight closure against the reverse flow of liquid caused by backsiphonage or backpressure. The modular cam-check includes a stainless steel spring and cam-arm, rubber faced disc and a replaceable seat. There shall be no brass or bronze parts used within the cam-check valve assembly. The valve cover shall be held in place through the use of a single grooved style two-bolt coupling. The main assembly shall consist of two independently operating torsion spring check assemblies, two resilient seated isolation valves, and four ball valve type test cocks. The assembly shall be an Ames Company Series 2000SS.

Materials

All internal metal parts: 300 Series stainless steel

Main valve body: 300 Series stainless steel
Check assembly: Noryl®

Flange dimension in accordance with AWWA Class D

Noryl® is a registered trademark of General Electric Company.

Pressure — Temperature

Temperature Range: 33°F – 110°F (5°C – 43°C)

Maximum Working Pressure: 175psi (12.06 bar)

NOTICE

The information contained herein is not intended to replace the full product installation and safety information available or the experience of a trained product installer. You are required to thoroughly read all installation instructions and product safety information before beginning the installation of this product.

Standards

AWWA C510-92, CSA B64.5

Approvals



1015



(OSY ONLY)

For 12" approvals
consult factory

Capacities

Rated working pressure 175psi (12.06 bar) * Rated flow **UL Tested

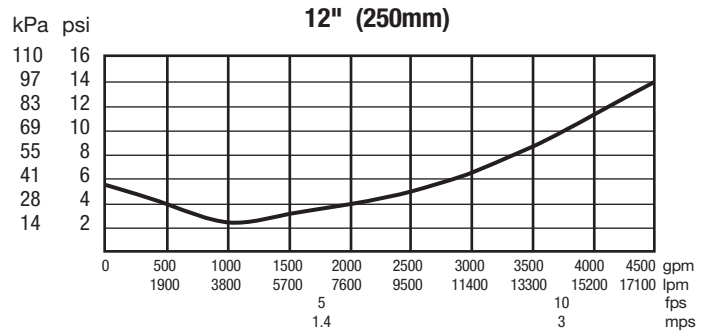
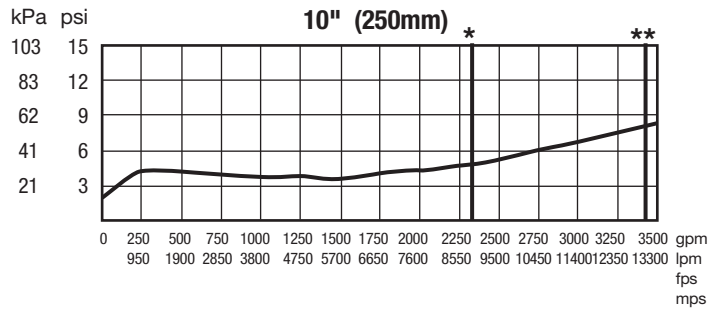
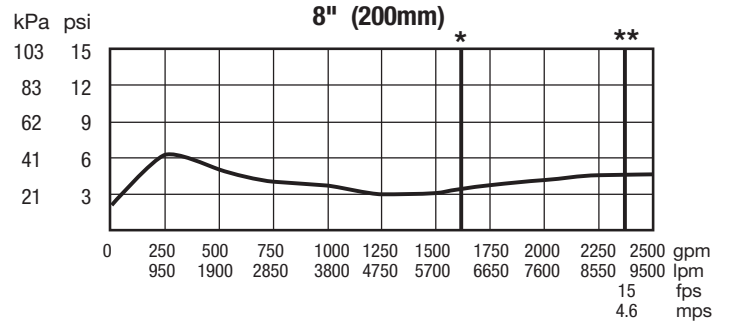
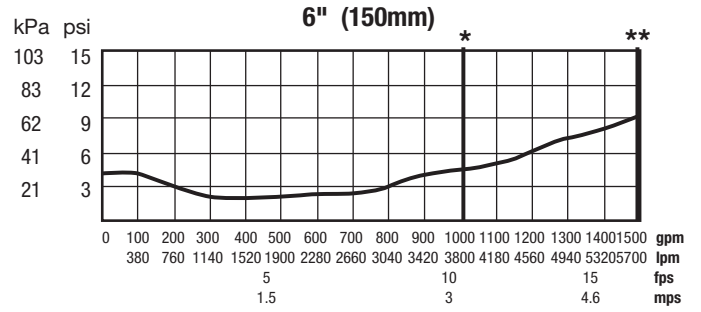
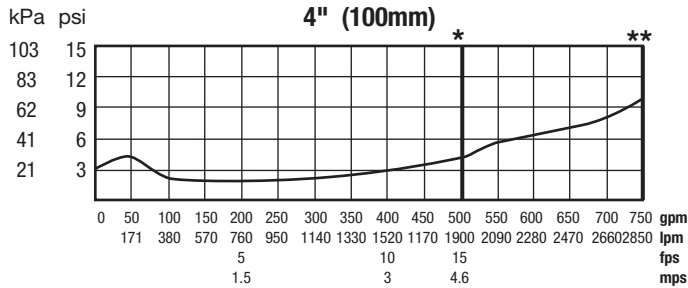
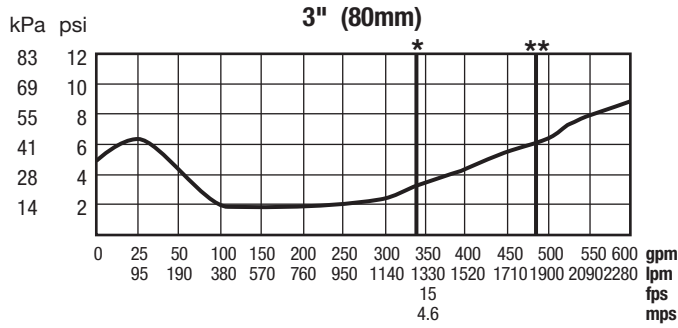
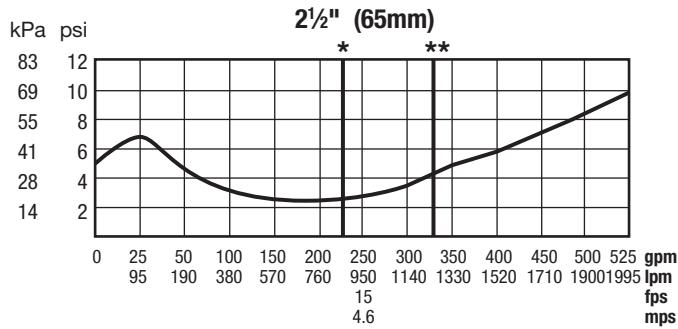

Dimensions – Weights

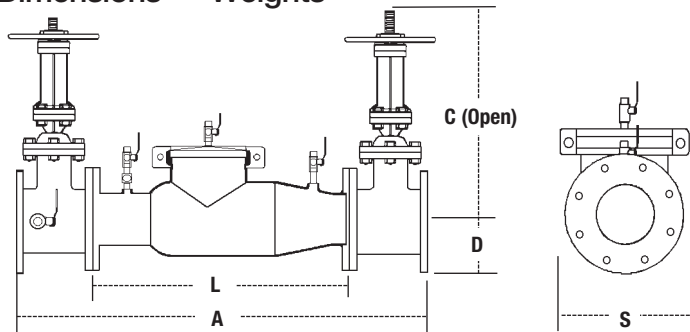

SIZE (DN)		DIMENSIONS										WEIGHT					
in.	mm	A		C (OSY)		C(NRS)		D		L		S		w/Gates		w/o Gates	
		in.	mm	in.	mm	in.	mm	in.	mm	in.	mm	in.	mm	lb.	kg.	lb.	kg.
2½	65	37	965	16¾	416	9¾	238	3½	89	22	559	7	178	140	64	53	24
3	80	38	965	18¾	479	10¼	260	3¾	95	22	559	7½	191	215	98	55	25
4	100	40	1016	22¾	578	12¾	310	4½	114	22	559	9	229	225	102	58	26
6	150	48½	1232	30½	765	16	406	5½	140	27½	699	11	279	375	170	105	48
8	200	52½	1334	37¾	959	19½	506	6¾	171	29½	749	13½	343	561	254	169	77
10	250	55½	1410	45¾	1162	23½	605	8	200	29½	749	16	406	763	346	179	81
12	300	57½	1461	53¾	1349	26¾	679	9½	241	29½	749	19	483	1033	469	209	95



A WATTS Brand

USA: Backflow T: (978) 689-6066 • F: (978) 975-8350 • AmesFireWater.com
 USA: Control Valves T: (713) 943-0688 • F: (713) 944-9445 • AmesFireWater.com
 Canada: T: (905) 332-4090 • F: (905) 332-7068 • AmesFireWater.ca
 Latin America: T: (52) 81-1001-8600 • AmesFireWater.com

For Non-Health Hazard Applications

Job Name _____
 Job Location _____
 Engineer _____
 Approval _____

Contractor _____
 Approval _____
 Contractor's P.O. No. _____
 Representative _____

LEAD FREE*

Series 850 Double Check Valve Assemblies

Size: 1/2" - 2" (15mm - 50mm)

The FEBCO Series 850 Double Check Valve Assemblies are designed for non-health hazard applications. End Connections – NPT ANSI / ASME B1.20.1

Pressure – Temperature

Max. Working Pressure: 175psi (12.1 bar)
 Hydrostatic Test Press: 350psi (24.1 bar)
 Temperature Range: 32°F to 140°F (0°C to 60°C)

Materials

Valve Body: Bronze
 Elastomers: Silicone
 Springs: Stainless Steel

Models

- Wye - Strainer

Approvals – Standards

- ANSI/AWWA Conformance (C510-92)
- Approved by the Foundation for Cross-Connection Control and Hydraulic Research at the University of Southern California.



Typical Installation

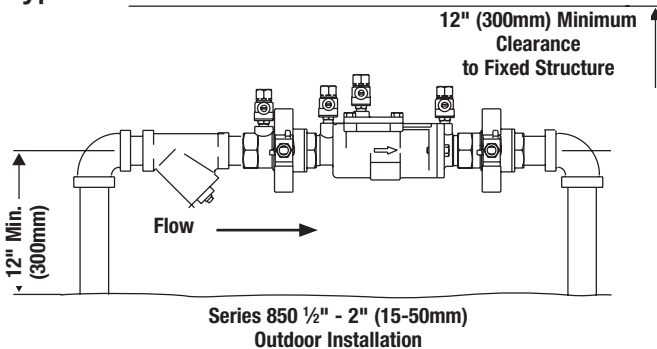

WARNING

It is illegal to use this product in any plumbing system providing water for human consumption, such as drinking or dishwashing, in the United States. Before installing standard material product, consult your local water authority, building and plumbing codes.

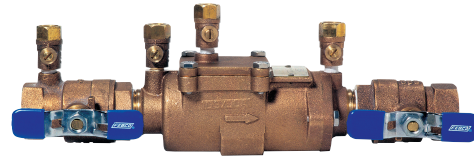

Series 850

Capacity

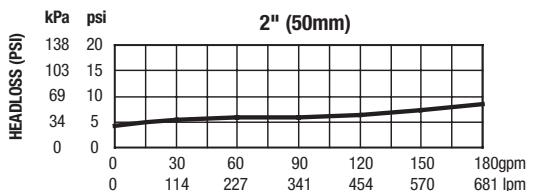
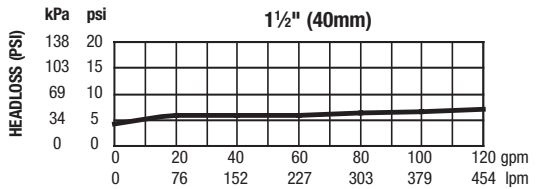
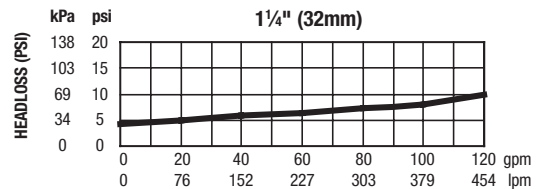
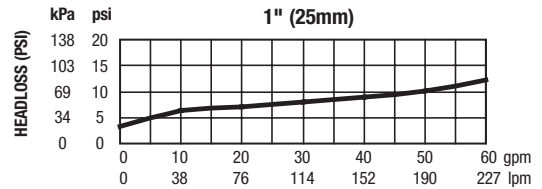
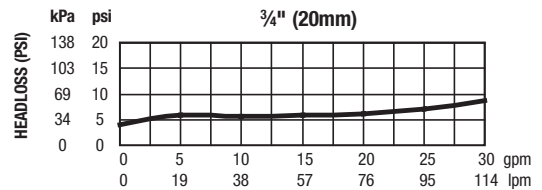
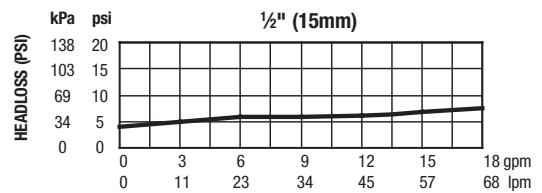

A WATTS Brand

FEBCO product specifications in U.S. customary units and metric are approximate and are provided for reference only. For precise measurements, please contact FEBCO Technical Service. FEBCO reserves the right to change or modify product design, construction, specifications, or materials without prior notice and without incurring any obligation to make such changes and modifications on FEBCO products previously or subsequently sold.

Series 850 / Size: 1/2" - 2" (15mm - 50mm)

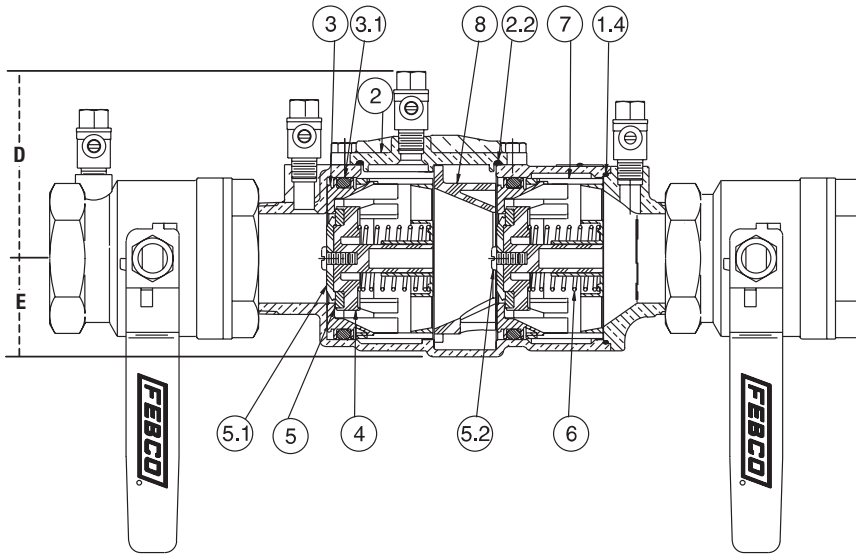

ITEM	DESCRIPTION	MATERIALS
1	Body	Bronze
1.2	Tailpiece	Bronze
1.4	O-Ring	Silicone
2	Cover	Bronze
2.2	O-Ring	Silicone
3	Seat	Noryl®
3.1	O-Ring	Silicone
4	Poppet	Noryl®
5	Seat Disc	Silicone
5.1	Disc Retainer	Noryl®
5.2	Rnd HD Screw	Stainless Steel
6	Spring	Stainless Steel
7	Guide	Noryl®
8	Retainer Spacer	Noryl®
9	Ball Valve (w/tap)	Bronze
9.1	Ball Valve	Bronze
11	Test Cock	Bronze
21	Hex HD Capscrew	Stainless Steel
60	Identification Plate	Brass
61	Drive Screw Stick	Stainless Steel

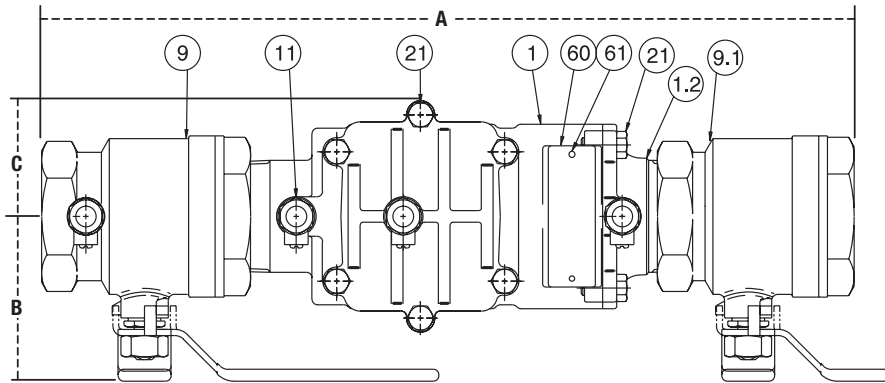

Check Assembly

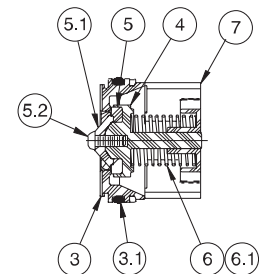

Dimensions and Weights

Size: 1/2" - 2" (15 - 50mm)

SIZE (DN)		DIMENSIONS										WEIGHT	
		A		B		C		D		E			
in.	mm	in.	mm	in.	mm	in.	mm	in.	mm	in.	mm	lbs.	kgs.
1/2	15	10	254	1 1/2	38	1 1/2	38	3 3/8	79	1 1/4	32	4.2	1.9
3/4	20	10 3/4	273	1 1/2	38	1 1/2	38	3 3/8	79	1 1/4	32	4.4	2.0
1	25	12 1/2	318	1 7/8	48	1 5/8	41	3 3/8	86	1 1/2	38	6.8	3.1
1 1/4	32	15 3/8	403	3	76	2 1/2	64	4 1/4	108	2 1/4	57	15.8	7.2
1 1/2	40	16 3/8	416	3	76	2 1/2	64	4 1/4	108	2 1/4	57	16.2	7.4
2	50	17 3/8	450	3 1/2	89	2 1/2	64	4 1/4	108	2 1/4	57	21.1	9.6

Dimensions are nominal. Allowances must be made for normal manufacturing tolerances.



A WATTS Brand

USA: Tel: (800) 767-1234 • Fax: (800) 788-4491 • FEBCOonline.com
 Canada: Tel: (905) 332-4090 • Fax: (905) 332-7068 • FEBCOonline.ca
 Latin America: (52) 81-1001-8600 • Fax: (52) 81-8000-7091 • FEBCOonline.com

For Non-Health Hazard Applications

Job Name _____

Contractor _____

Job Location _____

Approval _____

Engineer _____

Contractor's P.O. No. _____

Approval _____

Representative _____

LEAD FREE*

MasterSeries® LF850

Double Check Valve Backflow Prevention Assemblies

Sizes: 2½" – 10"

The FEBCO MasterSeries LF850 Double Check Assembly is specifically designed to protect against possible backpressure and backsiphonage conditions for non-health hazard (i.e., pollutant) application in accordance with Local Governing Water Utility Code. This Backflow Assembly is primarily used on potable drinking water systems where Local Governing Code mandates protection from non-potable quality water being pumped or siphoned back into the potable water system.

The LF850 features Lead Free* construction to comply with low lead installation requirements. The Lead Free* Double Check Assemblies shall comply with state codes and standards, where applicable, requiring reduced lead content.

Features

- Inline Serviceable Assembly
- No Special Tools Required for Servicing
- Captured Modular Spring Assembly
- Reversible & Replaceable Discs
- Field Replaceable Seats
- Ductile Iron Valve Body Design
- Stainless Steel Check Components
- Winterization feature with disc retainers and valve body drain ports
- Clapper Check Assembly
- Commonality between 1st & 2nd Check Components
- Captured O-ring Design



Model LF850 Double Check Assembly

Specifications

The FEBCO MasterSeries LF850 Double Check Valve Assembly shall be installed on the potable water supply and at each point of cross-connection to protect against possible backpressure and backsiphonage conditions for non-health hazard (i.e., pollutant) applications. The assembly shall consist of a main line valve body composed of two (2) independently acting approved clapper style check modules with replaceable seats and disc rubbers. Servicing of both check modules does not require any special tools and are accessed through independently top entry covers. This assembly shall be fitted with AWWA Compliant inlet/outlet resilient seated shutoff valves; when used on a Fire-Sprinkler application, the assembly shall be fitted with approved UL/FM inlet/outlet resilient seated shutoff valves and contain four (4) properly located resilient seated test cocks as specified by AWWA Standard C510. Flow and pressure loss performance parameters shall meet the requirements of AWWA Standard C510.

NOTICE

The information contained herein is not intended to replace the full product installation and safety information available or the experience of a trained product installer. You are required to thoroughly read all installation instructions and product safety information before beginning the installation of this product.

NOTICE

Inquire with governing authorities for local installation requirements

*The wetted surface of this product contacted by consumable water contains less than 0.25% of lead by weight.

FEBCO product specifications in U.S. customary units and metric are approximate and are provided for reference only. For precise measurements, please contact FEBCO Technical Service. FEBCO reserves the right to change or modify product design, construction, specifications, or materials without prior notice and without incurring any obligation to make such changes and modifications on FEBCO products previously or subsequently sold.



A WATTS Brand

Options - Suffix

- OSY: UL/FM Approved OS&Y Gate Valves
(ANSI/AWWA C515 Compliant)
- NRS: Non-Rising Stem Gate Valves
(ANSI/AWWA C509 Compliant)
- LG: Less Shut-off valves; This is NOT an APPROVED ASSEMBLY

Example Ordering Descriptions:

- 4" LF850-OSY - Valve Assembly fitted with OS&Y Shutoff Valves
- 4" LF850-NRS - Valve Assembly fitted with NRS Shutoff Valves

Assembly Flow Orientation:

Horizontal & Vertical Up (2½" – 10") - Approved by FCCCHR-USC, ASSE, cULus, FM, IAPMO, and CSA

Approvals – Standards

- Approved by the Foundation for Cross-Connection Control and Hydraulic Research at The University of Southern California (FCCCHR-USC)
 - ASSE 1015 Listed
 - **UL Classified (US & Canada)
 - **FM Approved
 - IAPMO
 - CSA Listed
 - AWWA Standard C510 Compliant
 - End Connections: Compliant to ASME B16.1 Class 125 & AWWA Class D Flange
- **Assembly configured with UL/FM Approved OS&Y RW Gate Valves. Less gate valve assemblies are not UL/FM approved configurations.



Materials

Below is a general materials list of the Model LF850. All assemblies size 2½" through 10" is similar in materials and construction. Please contact your local FEBCO Representative if you require further information.

- Main Valve Body: Ductile iron Grade 65-45-12
- Coating: Fusion epoxy coated internal and external AWWA C550
- Shutoff Valves: NRS resilient wedge gate valves AWWA C509 (Standard)
OSY resilient wedge gate valves AWWA C515 (UL/FM)
- Check Seats: Stainless Steel
- Disc Holder: Stainless Steel
- Elastomer Disc: Silicone
- Spring: Stainless Steel
- Clamp: AWWA C606 (10" Only)

Pressure – Temperature

- Max. Working Pressure: 175psi (12.1 bar)
- Min. Working Pressure: 10psi (0.7 bar)
- Hydrostatic Test Pressure: 350psi (24.1 bar)
- Hydrostatic Safety Pressure: 700psi (48.3 bar)
- Temperature Range: 33°F - 140°F (0.5°C - 60°C)
Continuous

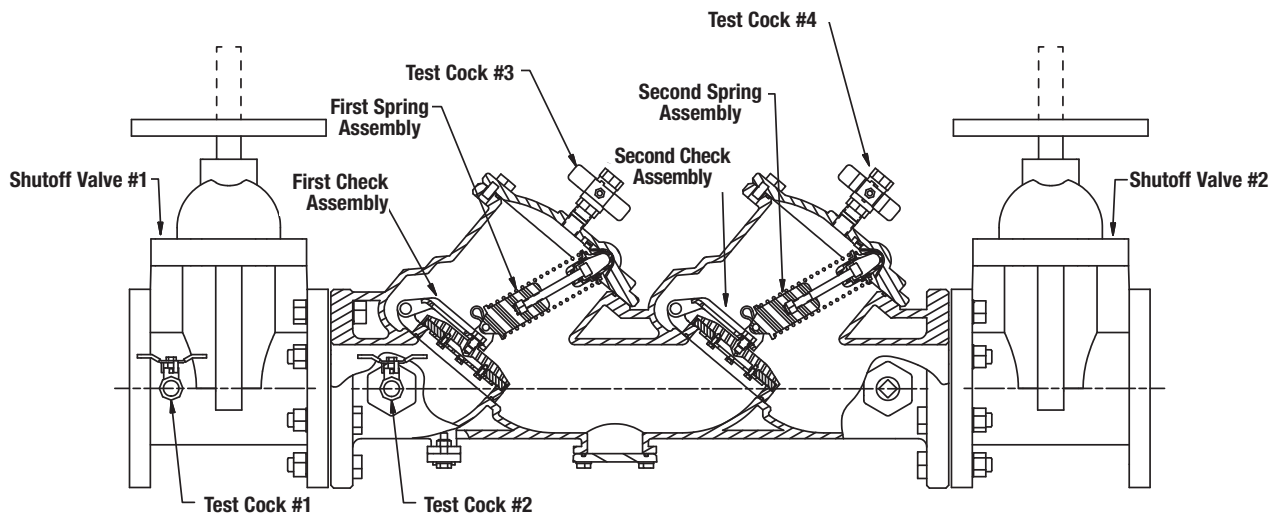

Application

Ideal for use where Lead-Free* valves are required. Designed for installation on potable water lines to protect against both backsiphonage and backpressure of polluted water into the potable water supply. A test cock plug is provided to protect against fouling caused by insects, dirt and debris. Assembly shall provide protection where a potential non-health hazard exists.

Standards Compliance

- (Unless otherwise noted, applies to 3/4" thru 2" Horizontal)
- ASSE® Listed 1015 (Vertical flow-up:1 1/4" thru 2")
- IAPMO® Listed
- CSA® Certified (Vertical flow-up:1 1/2" & 2")
- AWWA Compliant C510
- Approved by the Foundation for Cross Connection Control and Hydraulic Research at the University of Southern California
- Meets the requirements of NSF/ANSI 61*
*(0.25% MAX. WEIGHTED AVERAGE LEAD CONTENT)

Materials

Main valve body	Low Lead Cast Bronze ASTM B 584
Access covers	Low Lead Cast Bronze ASTM B 584
Fasteners	Stainless Steel, 300 Series
Elastomers	Silicone (FDA approved) Buna Nitrile (FDA approved)
Polymers	Noryl™
Springs	Stainless steel, 300 series
Test cock cover	Plastic
Ball valve handles	Stainless steel

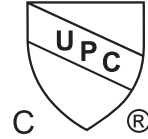

Features

Sizes: 3/4", 1", 1 1/4", 1 1/2", 2"	
Maximum working water pressure	175 PSI
Maximum working water temperature	180°F
Hydrostatic test pressure	350 PSI
End connections Threaded	ANSI B1.20.1

Options (Suffixes can be combined)

- FT - with "Fast Test" test cocks
- S - with Model SXL lead-free bronze "Y" type strainer
- PF - with Z-Bite™ push fit connections* (1/2"-1" only)
- PR - with Z-Press™ press fit connections*

*Fittings ship in box with valve and must be threaded into valve by hand on site.

Accessories

- Repair kit (rubber only)
- Thermal expansion tank (Model XT)
- QT-SET Quick Test Fitting Set

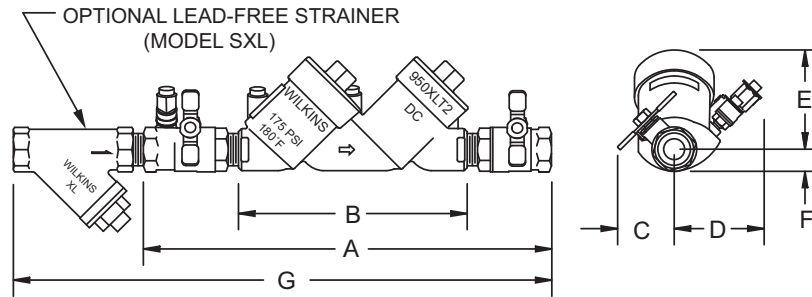

Dimensions & Weights (do not include pkg.)

MODEL SIZE		DIMENSIONS (approximate)														WITH BALL VALVES	
		A		B		C		D		E		F		G			
in.	mm	in.	mm	in.	mm	in.	mm	in.	mm	in.	mm	in.	mm	in.	mm	lbs.	kg
3/4	20	13	330	8 3/4	222	2 3/8	60	2 5/16	59	3 5/16	84	3/4	19	17 5/8	448	6	2.7
1	25	14	356	8 3/4	222	2 1/2	64	2 5/16	59	3 5/16	84	3/4	19	19 3/4	502	12	5.4
1 1/4	32	19 5/8	499	13 3/4	349	4	102	3 5/8	92	4 3/8	111	1 5/16	33	24 3/4	629	22	10
1 1/2	40	20 5/16	516	13 3/4	349	5 3/8	137	3 5/8	92	4 3/8	111	1 5/16	33	25 15/16	659	22	10
2	50	21 3/8	543	13 3/4	349	5 13/16	148	3 5/8	92	4 3/8	111	1 5/16	33	28 5/16	719	29	13.2

MODEL 950XLT2 3/4", 1", 1 1/4", 1 1/2" & 2" (STANDARD & METRIC)

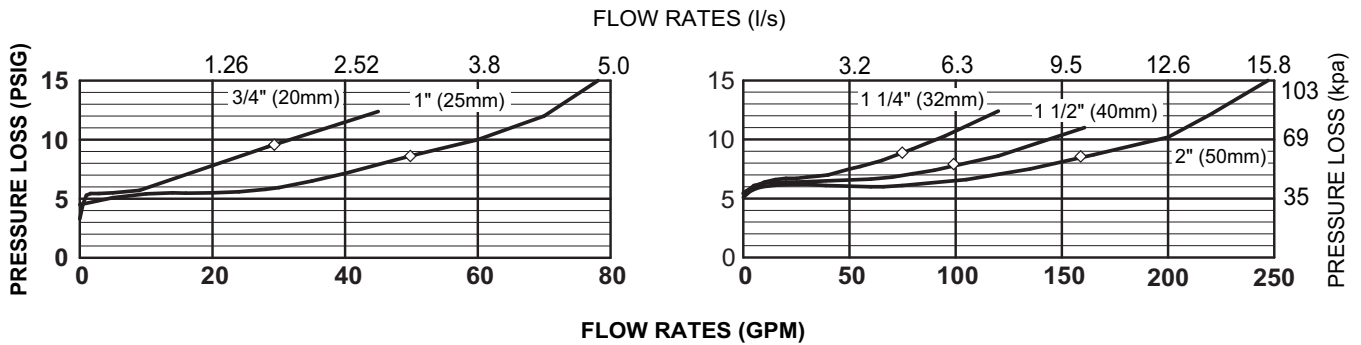

Typical Installation

Local codes shall govern installation requirements. To be installed in accordance with the manufacturer’s instructions and the latest edition of the Uniform Plumbing Code. Unless otherwise specified, the assembly shall be mounted at a minimum of 12" (305mm) and a maximum of 30" (762mm) above adequate drains with sufficient side clearance for testing and maintenance. If installed below grade, be certain adequate drainage is provided to prevent the device from being submerged.

Capacity thru Schedule 40 Pipe				
Pipe size	5 ft/sec	7.5 ft/sec	10 ft/sec	15 ft/sec
1/8"	1	1	2	3
1/4"	2	2	3	5
3/8"	3	4	6	9
1/2"	5	7	9	14
3/4"	8	12	17	25
1"	13	20	27	40
1 1/4"	23	35	47	70
1 1/2"	32	48	63	95
2"	52	78	105	167

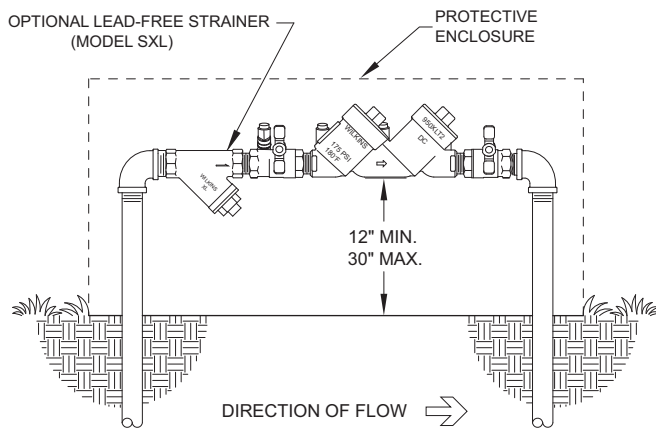

OUTDOOR INSTALLATION

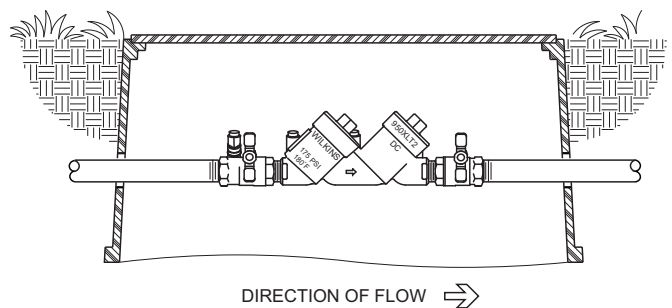

PIT INSTALLATION

Specifications

The Double Check Type Backflow Preventer shall be certified to NSF/ANSI 61, shall be ASSE Listed 1015, rated to 180°F, and supplied with full port ball valves. The main body and access covers shall be low lead bronze (ASTM B 584), the seat ring and all internal polymers shall be Noryl™ and the seat disc elastomers shall be SILICONE. The first and second check shall be located at a 45° angle and accessible for maintenance from the top of the device, without removing the device from the line. Each check shall have separate access covers and test cocks shall be accessible from the top of the device. Test cocks shall be protected from debris by a plug. The Double Check Type Backflow Preventer shall be a ZURN WILKINS Model 950XLT2.

REDUCED PRESSURE ASSEMBLY



Series LF4000B

Reduced Pressure Zone Assemblies

Sizes: 1/2" – 2"

LEAD FREE*

Features

- Single access cover and modular check construction for ease of maintenance
- Top entry - all internals immediately accessible
- Captured springs for safe maintenance
- Internal relief valve for reduced installation clearances
- Replaceable seats for economical repair
- Lead Free* cast silicon copper alloy construction for durability - 1/2" to 2"
- Ball valve test cocks - screwdriver slotted -1/2" to 2"
- Large body passages provides low pressure drop
- Compact, space saving design
- No special tools required for servicing

Available Models

Suffix:

B - quarter-turn ball valves

Pressure — Temperature

Suitable for supply pressures up to 175psi (12.1bar) and water temperature to 180°F (75°C) continuous.

Standards

AWWA C511, IAPMO File No. 1563

*The wetted surface of this product contacted by consumable water contains less than 0.25% of lead by weight.



1/2" LF4000B
(15mm)

Series LF4000B Reduced Pressure Zone Assemblies are designed to protect potable water supplies in accordance with national plumbing codes and water authority requirements. This series can be used in a variety of installations, including the prevention of health hazard cross connections in piping systems or for containment at the service line entrance.

This series features two in-line, independent check valves, captured springs and replaceable check seats with an intermediate relief valve. Its compact modular design facilitates easy maintenance and assembly access. Sizes 1/2"- 1" shutoffs have tee handles. The LF4000B features Lead Free* construction to comply with Lead Free* installation requirements.

Specifications

A Reduced Pressure Zone Assembly shall be installed at each potential health hazard location to prevent backflow due to backsiphonage and/or backpressure. Lead Free* Reduced Pressure Zone Assembly shall be constructed using Lead Free* materials. Lead Free assemblies shall comply with state codes and standards, where applicable, requiring reduced lead content. The assembly shall consist of an internal pressure differential relief valve located in a zone between two positive seating check modules with captured springs and silicone seat discs. Seats and seat discs shall be replaceable in both check modules and the relief valve. There shall be no threads or screws in the waterway exposed to line fluids. Service of all internal components shall be through a single access cover secured with stainless steel bolts. The assembly shall also include two resilient seated isolation valves, four resilient seated test cocks and an air gap drain fitting. The assembly shall meet the requirements of: USC; ASSE Std. 1013; AWWA Std. C511; CSA B64.4. The assembly shall be an Ames Company Series LF4000B.

Approvals

Approved by the Foundation for Cross-Connection Control and Hydraulic Research at the University of Southern California.



NOTICE

The information contained herein is not intended to replace the full product installation and safety information available or the experience of a trained product installer. You are required to thoroughly read all installation instructions and product safety information before beginning the installation of this product.

Job Name _____ Contractor _____

Job Location _____ Approval _____

Engineer _____ Contractor's P.O. No. _____

Approval _____ Representative _____

Ames product specifications in U.S. customary units and metric are approximate and are provided for reference only. For precise measurements, please contact Ames Technical Service. Ames reserves the right to change or modify product design, construction, specifications, or materials without prior notice and without incurring any obligation to make such changes and modifications on Ames products previously or subsequently sold.

Weights — Dimensions

LF4000B

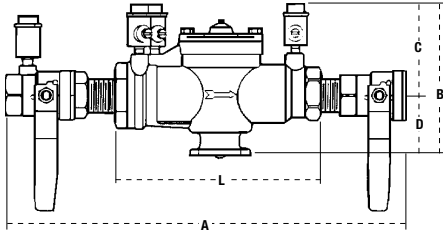

SIZE		DIMENSIONS								WEIGHT			
in.	mm	A		B		C		D		L		lbs.	kg.
1/2	10	250	4 3/8	117	3 3/8	86	1 1/4	32	5 1/2	140	4.50	2.0	
3/4	10 3/4	273	5	127	3 1/2	89	1 1/2	38	6 3/4	171	5.75	2.6	
1	14 1/2	368	5 1/2	140	3	76	2 1/2	64	9 1/2	241	12.25	5.6	
1 1/4	17 3/8	44	116	150	3 1/2	89	2 1/2	64	11 3/8	289	14.62	6.6	
1 1/2	17 3/8	454	6	150	3 1/2	89	2 1/2	64	11 1/8	283	16.32	7.4	
2	21 3/8	543	7 3/4	197	4 1/2	114	3 3/4	83	13 1/2	343	30.00	13.6	

Strainer sold separately

Capacity

Performance as established by an independent testing laboratory. ΔTypical maximum system flow rate (7.5 feet/sec., 2.3 meters/sec.)

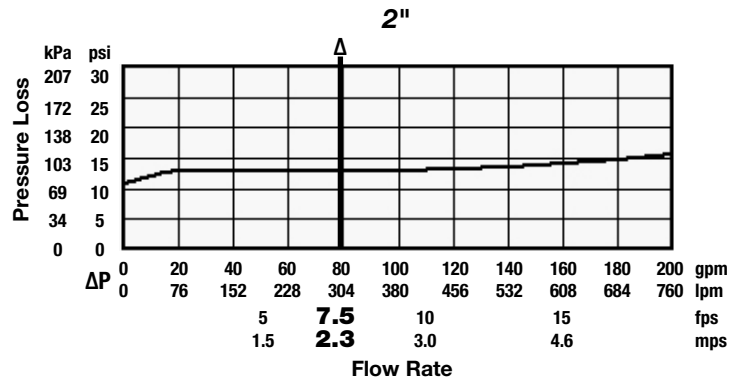
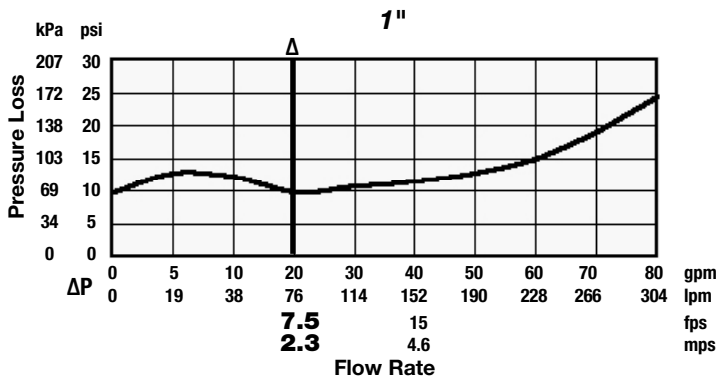
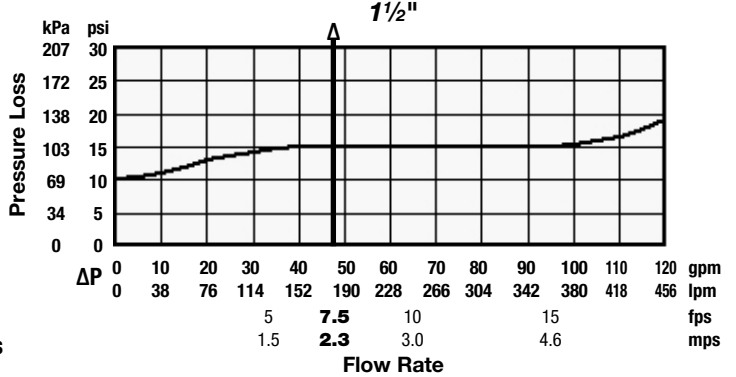
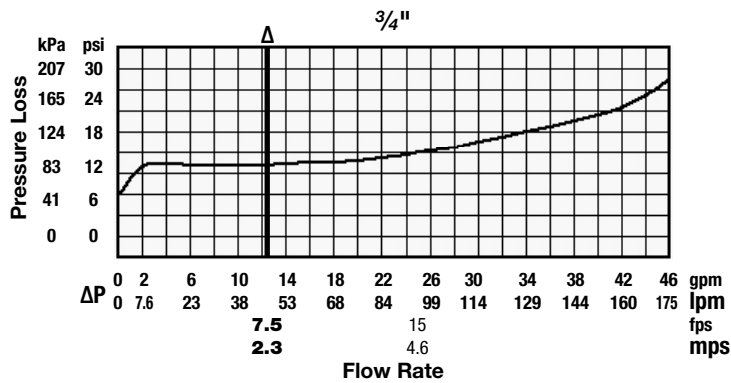
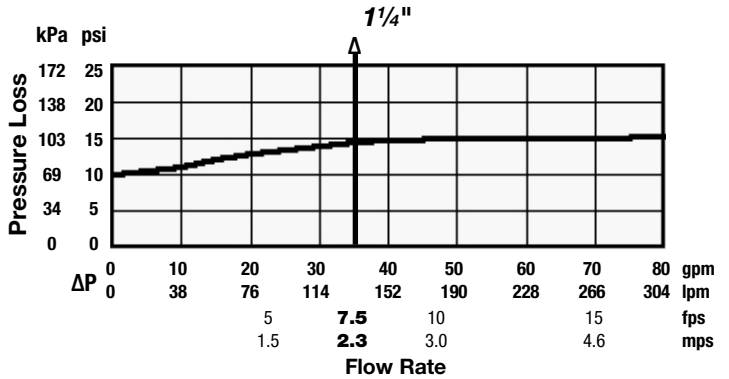
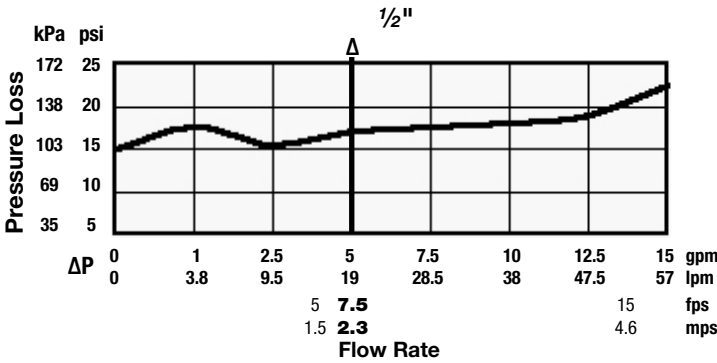

www.amesfirewater.com



ISO 9001-2008 CERTIFIED

A Watts Water Technologies Company

USA: Backflow- Tel: (916) 928-0123 • Fax: (916) 928-9333

Control Valves- Tel: (713) 943-0688 • Fax: (713) 944-9445

Canada: Tel: (905) 332-4090 • Fax: (905) 332-7068

ES-A-LF4000B 1406

VCCDD January 2025

Page 39

© 2014 Ames Fire & Waterworks



Series 4000SS

Reduced Pressure Zone Assemblies

Sizes: 2½" – 10" (65 – 250mm)

LEAD FREE*

Features

- Stainless steel construction provides long term corrosion resistance and maximum strength
- Stainless steel body is half the weight of competitive designs reducing installation & shipping costs
- Short end-to-end dimensions makes retrofit easy
- Cam-check assembly provides maximum flow at low pressure drop
- No special tools required for servicing
- Compact construction allows for smaller enclosures
- Stainless steel relief valve features a balanced rolling diaphragm to eliminate sliding seals and lower maintenance costs



Series 4000SS Reduced Pressure Zone Assemblies are designed to provide protection of the potable water supply in accordance with national codes. This series can be used where approved by the local authority having jurisdiction on health-hazard cross-connections. Series 4000SS features short lay length, lightweight stainless steel body, corrosive resistant stainless steel relief valve, and patented cam-check assembly.

Available Models

Suffix:

- NRS – non-rising stem resilient seated gate valves
- OSY – UL/FM outside stem and yoke resilient seated gate valves
- **OSY FxG – flanged inlet gate connection and grooved outlet gate connection
- **OSY GxF – grooved inlet gate connection and flanged outlet gate connection
- **OSY GxG – grooved inlet gate connection and grooved outlet gate connection
- LG – less gates

Available with grooved NRS gate valves - consult factory**
Post indicator plate and operating nut available – consult factory**

**Consult factory for dimensions

NOTICE

The installation of a drain line is recommended. When installing a drain line, an air gap is necessary. The 4000SS should be installed with a minimum clearance of 12" between lowest point of the assembly and the floor drain or grade.

*The wetted surface of this product contacted by consumable water contains less than (0.25%) of lead by weight.

Specifications

A Reduced Pressure Zone Assembly shall be installed at each cross-connection to prevent backsiphonage and backpressure of hazardous materials into the potable water supply. The series 4000SS features Lead Free* construction to comply with Lead Free* installation requirements. The assembly shall consist of a pressure differential relief valve located in a zone between two positive seating cam-check assemblies. The main valve body shall be manufactured from 300 Series stainless steel for corrosion resistance. The cam-check assembly shall be of thermoplastic construction with stainless steel hinge pins, cam arm, and cam bearing. The cam-check assembly shall utilize a single torsion spring design to minimize pressure drop through the assembly. The cam-check assembly shall be modular and shall seal to the main valve body by the use of an O-ring. There shall be no brass or bronze parts used within the check assembly or relief valve. The use of seat screws to retain the check valve seat is prohibited. All internal parts shall be accessible through a single cover on the valve assembly securely held in place by a two-bolt grooved coupling. The differential relief valve shall be of stainless steel construction and shall utilize a rolling diaphragm and no sliding seals. The relief valve shall be bottom mounted and supplied with a steel reinforced sensing hose. The assembly shall include two resilient seated shutoff valves & four ball type test cocks. The assembly shall be an Ames Company Series 4000SS.

Standards

AWWA C511-92

Approvals



NOTICE

When installing a drain line on Series 4000SS backflow preventer, use air gap. See Literature ES-A-AG/EL/TC for additional information.

Job Name _____ Contractor _____

Job Location _____ Approval _____

Engineer _____ Contractor's P.O. No. _____

Approval _____ Representative _____

Ames product specifications in U.S. customary units and metric are approximate and are provided for reference only. For precise measurements, please contact Ames Technical Service. Ames reserves the right to change or modify product design, construction, specifications, or materials without prior notice and without incurring any obligation to make such changes and modifications on Ames products previously or subsequently sold.

Materials

All internal metal parts: 300 Series stainless steel
 Main valve body: 300 Series stainless steel
 Check assembly: Noryl®
 Flange dimension in accordance with AWWA Class D

Pressure — Temperature

Temperature Range: 33°F – 110°F (0.5°C – 43°C)
 Maximum Working Pressure: 175psi (12.1 bar)

Capacity

Series 4000SS performance as established by an independent testing laboratory (1996 UL). UL certified flow characteristics.

Documented flow characteristics (including shutoff valves).

*UL Rated **UL Tested

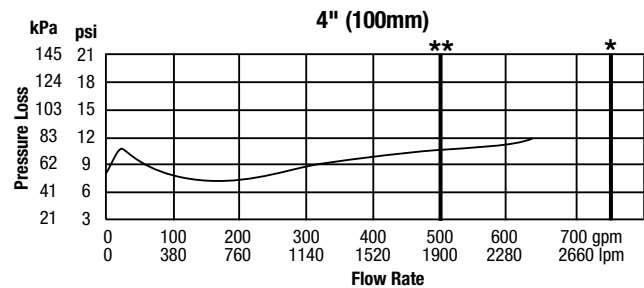
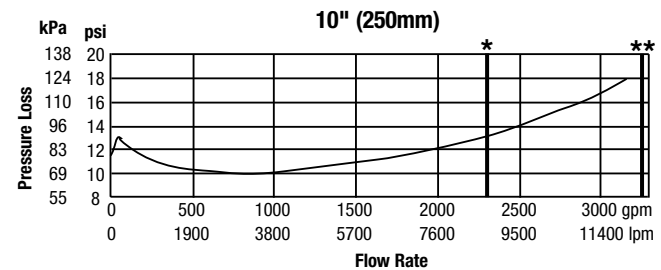
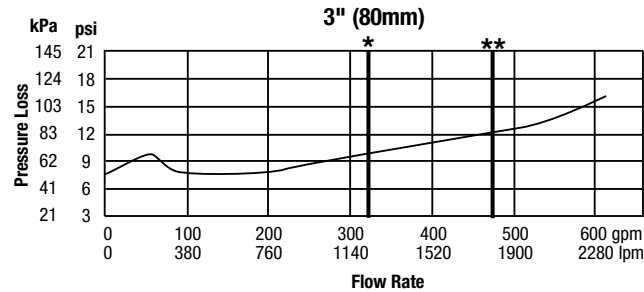
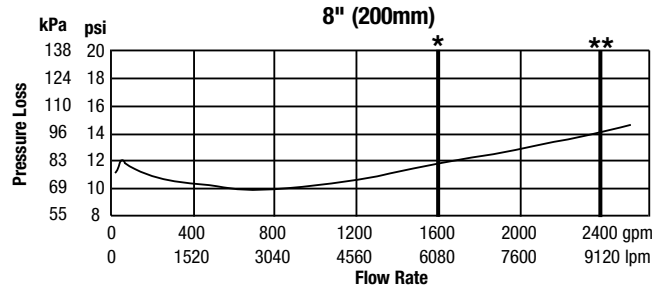
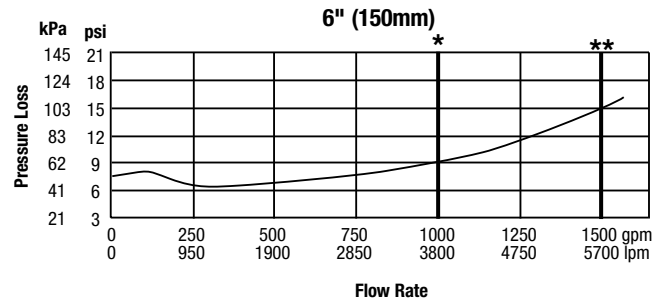
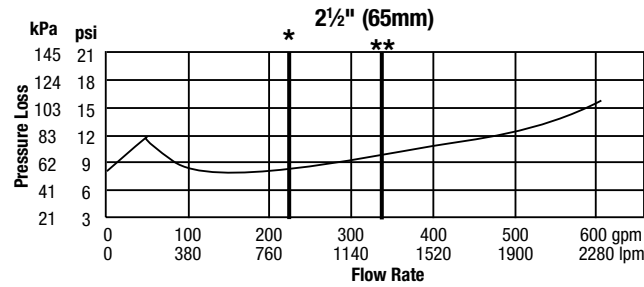

Dimensions – Weights

Note: Strainer sold separately

SIZE		DIMENSIONS							NET WEIGHT								
in.	mm	A		C (OSY)		C (NRS)		D		F		L		w/Gates		w/o Gates	
		in.	mm	in.	mm	in.	mm	in.	mm	in.	mm	in.	mm	lb.	kg.	lb.	kg.
2½	65	37	940	16¾	416	9¾	238	10½	267	7	178	22	559	148	67	60	27
3	80	38	965	18⅞	479	10¼	260	10½	267	7½	191	22	559	226	103	62	28
4	100	40	1016	22¾	578	12¾	310	10½	267	9	229	22	559	235	107	65	30
6	150	48½	1232	30⅞	765	16	406	11½	292	11	279	27½	699	380	172	110	50
8	200	52½	1334	37¼	959	19½	506	12½	318	13½	343	29½	749	571	259	179	81
10	250	55½	1410	45¾	1162	23½	605	12½	318	16	406	29½	749	773	351	189	86

Noryl® is a registered trademark of General Electric Company



NOTICE

Inquire with governing authorities for local installation requirements

A Watts Water Technologies Company

USA: Backflow Tel: (978) 689-6066 • Fax: (978) 975-8350 • AmesFireWater.com
USA: Control Valves Tel: (713) 943-0688 • Fax: (713) 944-9445 • AmesFireWater.com
Canada: Tel: (905) 332-4090 • Fax: (905) 332-7068 • AmesFireWater.ca
Latin America: Tel: (52) 81-1001-8600 • Fax: (52) 81-8000-7091 • AmesFireWater.com

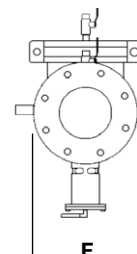
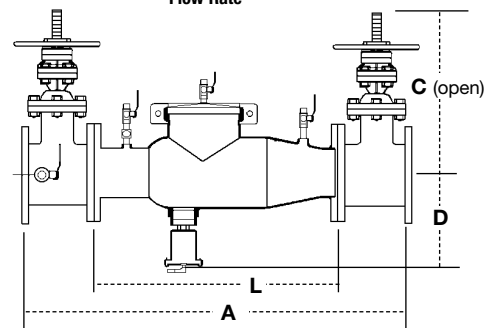

For Health Hazard Applications

Job Name _____

Contractor _____

Job Location _____

Approval _____

Engineer _____

Contractor's P.O. No. _____

Approval _____

Representative _____

LEAD FREE*

Series LF860

Reduced Pressure Zone Assemblies

Size: 1/2" - 2"

The FEBCO Series LF860 Reduced Pressure Zone Assemblies are designed for use in health-hazard applications. The LF860S features Lead Free* construction to comply with Lead Free* installation requirements. End Connections – NPT ANSI / ASME B1.20.1. The Lead Free* Reduced Pressure Zone Assemblies shall comply with state codes and standards, where applicable, requiring reduced lead content.

Pressure – Temperature

Max. Working Pressure: 175psi (12.1 bar)
 Hydrostatic Test Pressure: 350psi (24.1 bar)
 Temperature Range: 32°F to 140°F (0°C to 60°C)

Materials

Valve Body: Lead Free* Cast Copper Silicon Alloy
 Elastomers: Silicone
 Springs: Stainless Steel

Models

- LF860 - Standard Assembly with Ball Valves
- LF860U - Standard Assembly with Union Ball Valves

Approvals – Standards

- ANSI/AWWA Conformance (C511)
- Approved by the Foundation for Cross-Connection Control and Hydraulic Research at the University of Southern California.



Typical Installation

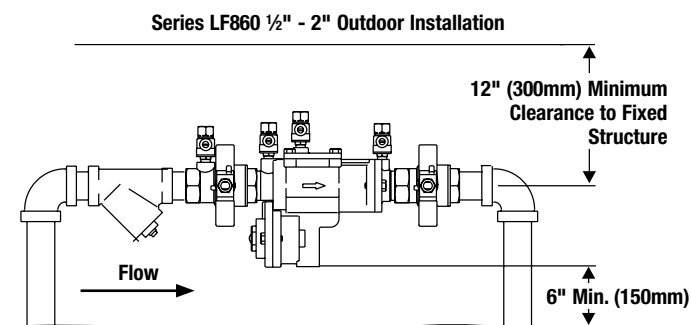

Series LF860

Capacity

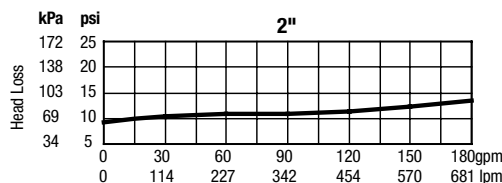
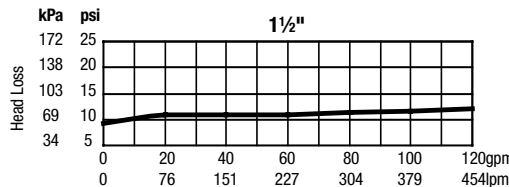
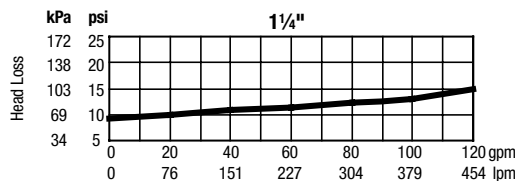
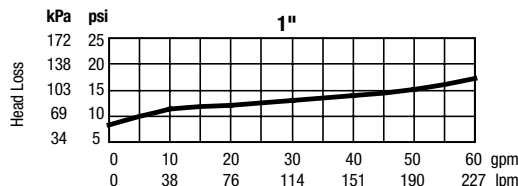
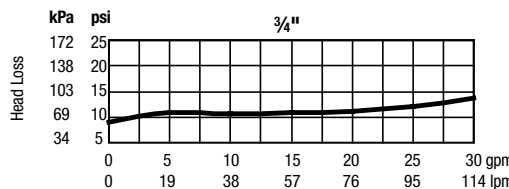
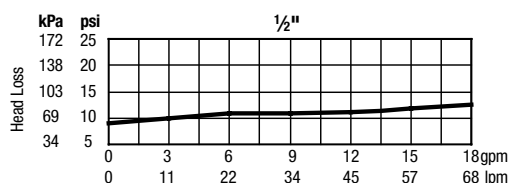

A WATTS Brand

FEBCO product specifications in U.S. customary units and metric are approximate and are provided for reference only. For precise measurements, please contact FEBCO Technical Service. FEBCO reserves the right to change or modify product design, construction, specifications, or materials without prior notice and without incurring any obligation to make such changes and modifications on FEBCO products previously or subsequently sold.

Series LF860 / Size: 1/2" - 2"

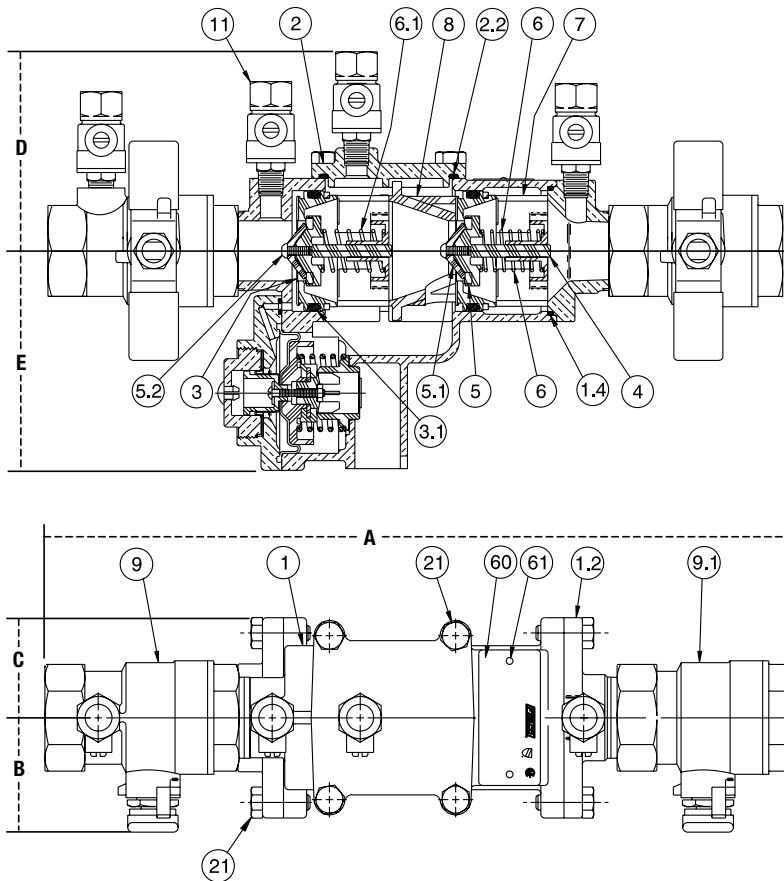

ITEM	DESCRIPTION	MATERIALS
1	Body	Lead Free* Cast Copper Silicon Alloy
1.2	Tailpiece	Lead Free* Cast Copper Silicon Alloy
1.4	O-Ring	Silicone
2	Cover	Lead Free* Cast Copper Silicon Alloy
2.2	O-Ring	Silicone
3	Seat	Noryl®
3.1	O-Ring	Silicone
4	Poppet	Noryl®
5	Seat Disc	Silicone Rubber
5.1	Disc Retainer	Noryl®
5.2	Rnd HD Screw	Phillips, 18-8 SS
6	Spring	SS
6.1	Spring	SS
7	Guide	Noryl®
8	Retainer Spacer	Noryl®
9	Ball Valve (w/tap)	Lead Free* Cast Copper Silicon Alloy
9.1	Ball Valve	Lead Free* Cast Copper Silicon Alloy
11	Test Cock	Lead Free* Cast Copper Silicon Alloy
12	Seat Ring-RV	Noryl®
12.1	Gasket Ring-RV	Silicone Rubber
13	Spring-RV	SS
14	Seat Disc-RV	Silicone Rubber/SS
15	Diaphragm-RV	Rubber/Fabric
16	Outer Diaphragm-RV	Rubber/Fabric
17	Small Piston-RV	Noryl®
17.1	Rnd HD Screw	Phillips, 18-8 SS
17.2	Washer	18-8 SS
17.3	Hex Nut	18-8 SS
18	Cylinder-RV	Lead Free* Cast Copper Silicon Alloy
18.1	Slip Ring-Cylinder	Acetal
18.2	Slide (Plug)	Nylon
19	Cover-RV	Lead Free* Cast Copper Silicon Alloy
20	O-Ring	Silicone
21	Hex HD Capscrew	18-8 SS
22	Large Piston-RV	Noryl®
23	Guide-RV	Noryl®
60	Identification Plate	Brass
61	Drive Screw Stick	SS

Relief Valve Assembly

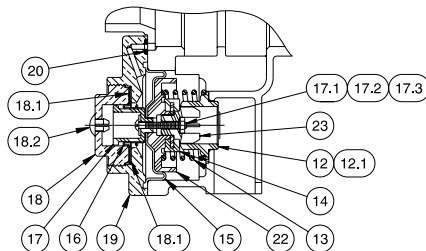

Check Assembly

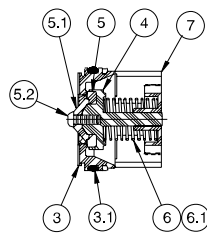

Dimensions – Weights

Size: 1/2" - 2"

SIZE	DIMENSIONS										WEIGHT	
	A		B		C		D		E		lbs.	kgs.
in.	mm	in.	mm	in.	mm	in.	mm	in.	mm			
1/2	10	254	1 1/2	38	1 1/2	38	3 1/8	79	3 1/2	89	5.6	2.5
3/4	10 3/4	273	1 1/2	38	1 1/2	38	3 1/8	79	3 1/2	89	5.8	2.6
1	12 1/2	318	1 7/8	48	1 5/8	41	3 3/8	86	3 5/8	92	9.2	4.2
1 1/4	15 7/8	403	3	76	2 1/2	64	4 1/4	108	5 1/8	143	20.6	9.2
1 1/2	16 3/8	416	3	76	2 1/2	64	4 1/4	108	5 1/8	143	20.6	9.2
2	17 3/8	450	3 1/2	89	2 1/2	64	4 1/4	108	5 1/8	143	24.8	11.3

Note: Dimensions are nominal. Allowances must be made for normal manufacturing tolerances.



A WATTS Brand

* The wetted surface of this product contacted by consumable water contains less than 0.25% of lead by weight.

Noryl® is a registered trademark of SABIC Innovative Plastics™.

NOTICE

The gap drain is not designed to catch the maximum discharge possible from the relief valve. The installation of FEBCO air gap with the drain line terminating above a floor drain will handle any normal discharge or nuisance spitting through the relief valve. However, floor drain size may need to be designed to prevent water damage caused by a catastrophic failure condition. Do not reduce the size of the drain line from the air gap fitting.

NOTICE

Inquire with governing authorities for local installation requirements.

NOTICE

The information contained herein is not intended to replace the full product installation and safety information available or the experience of a trained product installer. You are required to thoroughly read all installation instructions and product safety information before beginning the installation of this product.

USA: Tel: (800) 767-1234 • Fax: (800) 788-4491 • FEBCOonline.com
 Canada: Tel: (905) 332-4090 • Fax: (905) 332-7068 • FEBCOonline.ca
 Latin America: (52) 81-1001-8600 • FEBCOonline.com

Job Name _____

Contractor _____

Job Location _____

Approval _____

Engineer _____

Contractor's P.O. No. _____

Approval _____

Representative _____

LEAD FREE*

MasterSeries® LF860

Reduced Pressure Zone Backflow Prevention Assemblies

Size: 2½" - 10"

The FEBCO MasterSeries LF860 Reduced Pressure Zone Assembly is specifically designed to protect against possible backpressure and backsiphonage conditions for high hazard [i.e., toxic] application in accordance with Local Governing Water Utility Code. This Backflow Prevention Assembly is primarily used on potable drinking water systems where Local Governing Code mandates protection from non-potable water being pumped or siphoned back into the potable water system.

The coating on this backflow assembly uses ArmorTek™ technology to resist corrosion due to microbial induced corrosion (MIC) or exposed metal substrate. The LF860 features Lead Free* construction to comply with low lead installation requirements. The Lead Free* Reduced Pressure Zone Assemblies shall comply with state codes and standards, where applicable, requiring reduced lead content.

Series LF860 is also available with SentryPlus™ Alert technology to detect catastrophic relief valve discharge that could potentially cause flooding, and issue a multi-channel alert (call, email, text) to selected users so they can take action to avoid potentially costly flooding.

Features

- Inline Serviceable Assembly
- No Special Tools Required for Servicing
- Captured Modular Spring Assembly
- Reversible & Replaceable Discs
- Field Replaceable Seats
- Ductile Iron Valve Body Design
- Stainless Steel Check Components
- Utilizes advanced ArmorTek™ coating technology to resist corrosion of internals
- Modular Pressure Differential Relief Valve
- Repairable Pressure Differential Relief Valve
- Clapper Check Assembly
- Captured O-ring Design

**MASTER
series®****Series LF860 Reduced Pressure Zone Assembly**

Specifications

The FEBCO MasterSeries LF860 Reduced Pressure Zone Assembly shall be installed on the potable water supply and at each point of cross-connection to protect against possible backpressure and backsiphonage conditions for high hazard [i.e., toxic] applications. The assembly shall consist of a main line valve body composed of a pressure differential relief valve located in a zone between two (2) independently acting approved clapper style check modules with replaceable seats and disc rubbers. Servicing of the pressure differential relief valve and both check modules does not require any special tools; both check modules are accessed through independently top entry covers. This assembly shall be fitted with AWWA Compliant inlet/outlet resilient seated shutoff valves; when used on a Fire-Sprinkler application, the assembly shall be fitted with approved UL/FM inlet/outlet resilient seated shutoff valves and contain four (4) properly located resilient seated test cocks as specified by AWWA Standard C511. The valve body shall utilize a coating system with built in electrochemical corrosion inhibitor and microbial inhibitor. Flow and pressure loss performance parameters shall meet the requirements of AWWA Standard C511.

NOTICE

The information contained herein is not intended to replace the full product installation and safety information available or the experience of a trained product installer. You are required to thoroughly read all installation instructions and product safety information before beginning the installation of this product.

NOTICE

Inquire with governing authorities for local installation requirements

*The wetted surface of this product contacted by consumable water contains less than 0.25% of lead by weight.

FEBCO product specifications in U.S. customary units and metric are approximate and are provided for reference only. For precise measurements, please contact FEBCO Technical Service. FEBCO reserves the right to change or modify product design, construction, specifications, or materials without prior notice and without incurring any obligation to make such changes and modifications on FEBCO products previously or subsequently sold.

FEBCO®**A WATTS Brand**

Options - Suffix

- OSY: UL/FM Approved OS&Y Gate Valves
(ANSI/AWWA C515 Compliant)
- NRS: Non-Rising Stem Gate Valves
(ANSI/AWWA C509 Compliant)
- LG: Less Shut-off valves; This is NOT an APPROVED ASSEMBLY
- ALERT with SentryPlus™ Alert flood detection system

Example Ordering Descriptions:

- 4" LF860-OSY - Valve Assembly fitted with OS&Y Shutoff Valves
- 4" LF860-NRS - Valve Assembly fitted with NRS Shutoff Valves

Assembly Flow Orientation:

- Horizontal (2½" – 10") - Approved by FCCCHR-USC, ASSE, cULus, FM, IAPMO and CSA

Materials

Below is a general materials list of the Series LF860. All assemblies size 2½" through 10" is similar in materials and construction. Please contact your local FEBCO Representative if you require further information.

- Main Valve Body: Ductile iron Grade 65-45-12
- Relief Valve Body: Ductile iron Grade 65-45-12
- Coating: Fusion epoxy coated internal and external
AWWA C550
- Shutoff Valves: NRS resilient wedge gate valve AWWA C509
(Standard)
OSY resilient wedge gate valve AWWA C515
(UL/FM)
- Check Seats: Stainless Steel
- Disc Holder: Stainless Steel
- Elastomer Disc: Silicone
- Spring: Stainless Steel
- Clamp: AWWA C606 (10" Only)

Approvals - Standards

- Approved by the Foundation for Cross-Connection Control and Hydraulic Research at The University of Southern California (FCCCHR-USC)
 - ASSE 1013 Listed
 - **UL Classified (US & Canada)
 - **FM Approved
 - IAPMO
 - AWWA Standard C511 Compliant
 - End Connections: Compliant to ASME B16.1 Class 125 & AWWA Class D Flange
- **Assembly configured with UL/FM Approved OS&Y RW Gate Valves. Less gate valve assemblies are not UL/FM approved configurations.



Pressure - Temperature

Max. Working Pressure:	175 psi (12.1 bar)
Min. Working Pressure:	20 psi (1.4 bar)
Hydrostatic Test Pressure:	350 psi (24.1 bar)
Hydrostatic Safety Pressure:	700 psi (48.3 bar)
Temperature Range:	33°F - 140°F (0.5°C - 60°C) Continuous

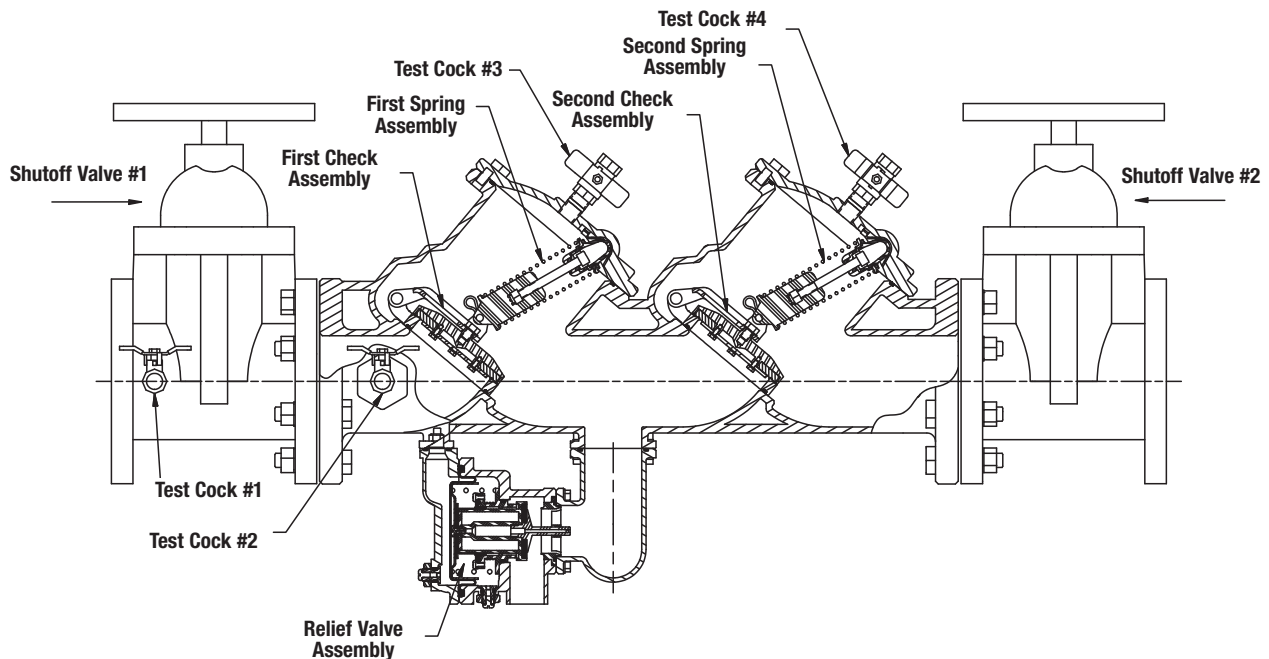

Dimensions & Weights

Below are the nominal dimensions and physical weights for the Series LF860 size 2½" through 10". Allowances must be made for normal manufacturing tolerances. Please visit our website to download a copy of this product's installation instructions, or contact your local FEBCO Representative for more information.

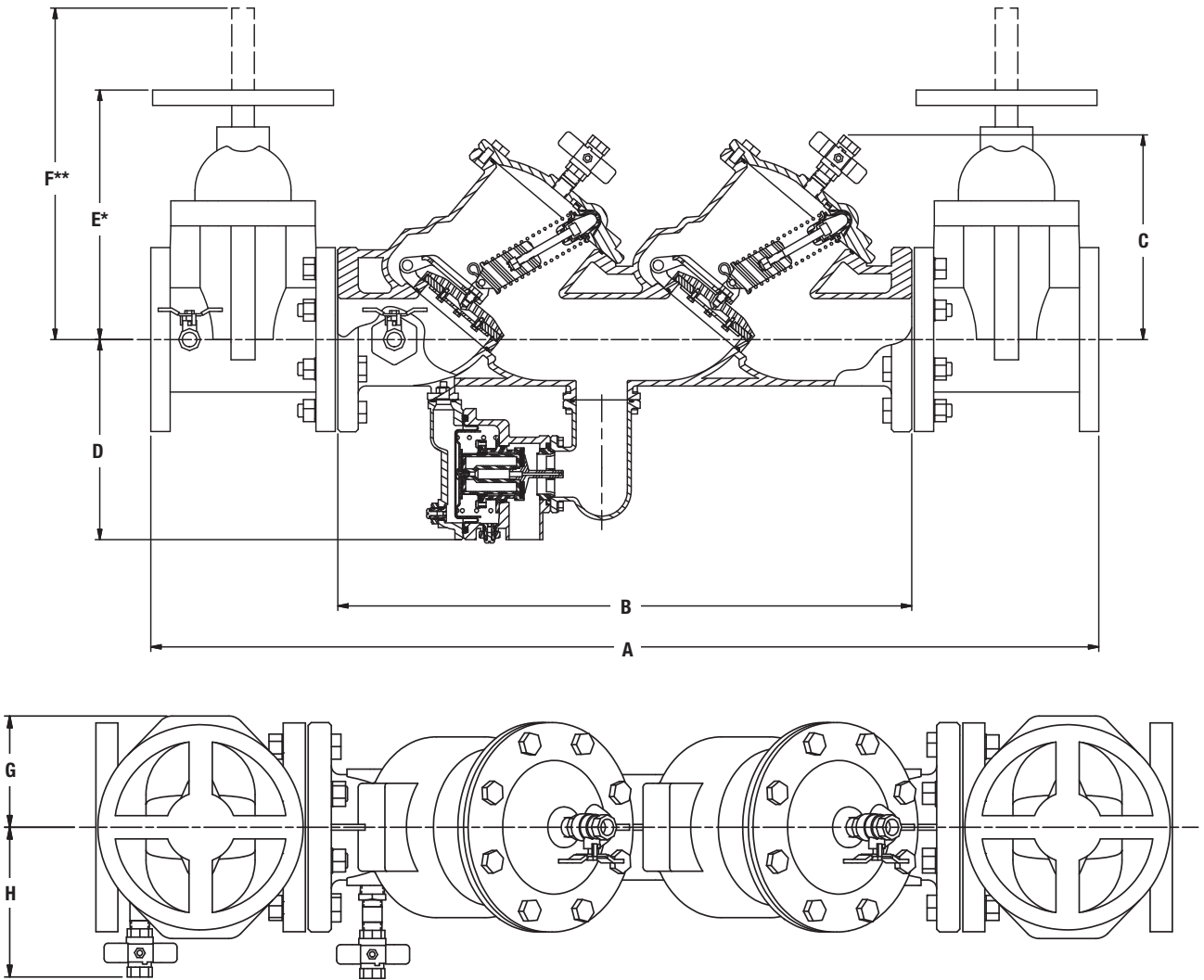

LF860

SIZE		DIMENSIONS										WEIGHT***									
		A		B		C		D		E*		F**		G		H		NRS		OSY	
in.	mm	in.	mm	in.	mm	in.	mm	in.	mm	in.	mm	in.	mm	in.	mm	in.	mm	lbs.	kg.	lbs.	kg.
2½	40¾	1035	25½	648	10	254	10	254	12⅝	321	16⅝	416	4½	114	7⅞	181	250	113	254	115	
3	41⅞	1064	25⅝	651	10	254	10	254	12⅞	327	22¼	565	4½	114	7⅞	187	276	125	280	127	
4	46¼	1175	28	711	10⅞	257	10⅞	257	14⅜	365	23¼	591	5½	140	8⅞	206	335	152	347	157	
6	56	1422	34¾	883	12¾	324	11⅞	283	18⅞	479	30⅞	765	6½	165	9⅞	251	503	228	523	237	
8	65	1651	41¾	1061	15⅝	397	12¼	311	23½	597	37¼	959	7	178	11⅞	283	807	366	835	379	
10	72⅝	1845	46⅝	1178	15⅞	397	12⅝	314	27½	699	48	1219	9	229	12⅝	314	1205	547	1243	564	

* Indicates nominal dimensions with NRS Gate Valves

** Indicates nominal dimensions with OSY Gate Valves (Full Open Position)

*** Indicates weight of complete Backflow Assemblies with specified Gate Valves

The gap drain is not designed to catch the maximum discharge possible from the relief valve. The installation of the FEBCO air gap with the drain line terminating above a floor drain will handle any normal discharge or nuisance spitting through the relief valve. However, floor drain size may need to be designed to prevent water damage caused by a catastrophic failure condition. Do not reduce the size of the drain line from the air gap fitting.

Performance

Flow capacity chart identifies valve performance based upon rated water Velocity up to 20fps

- Maximum service flow rate is determined by maximum rated Velocity of 7.5fps.
- AWWA Manual M-22 (Appendix C) recommends that the maximum water Velocity in the services be not more than 10fps.
- UL flow rate is determined by typically rated Velocity of 15 feet/sec.

Capacity

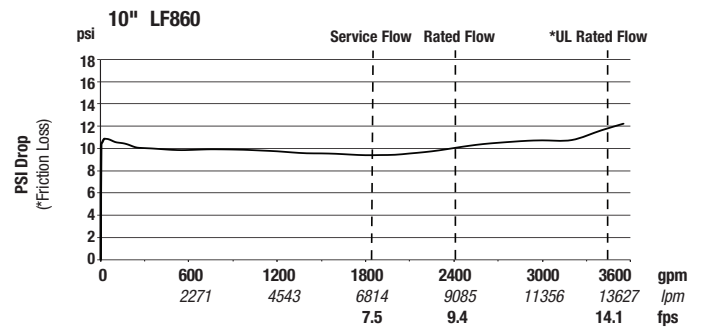
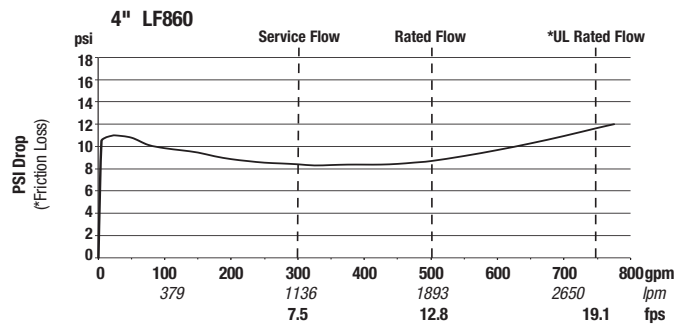
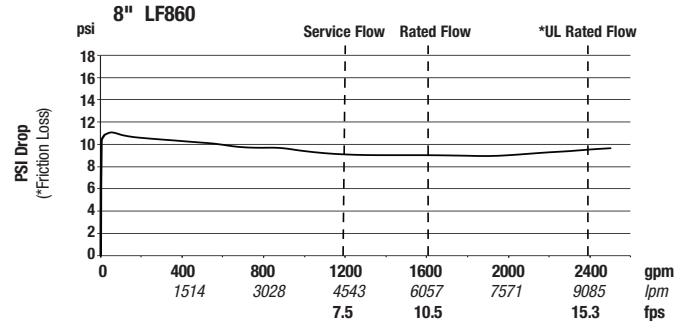
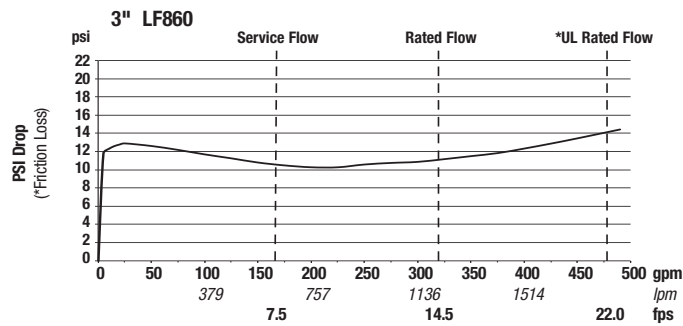
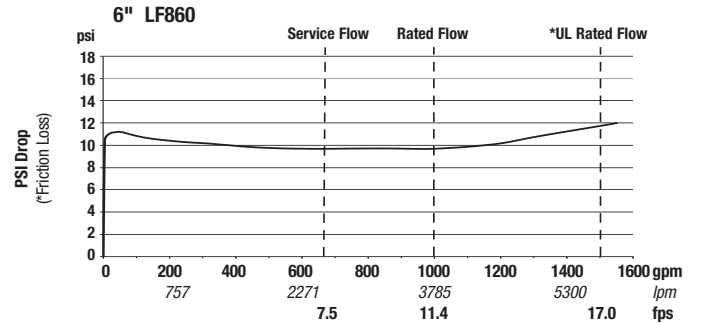
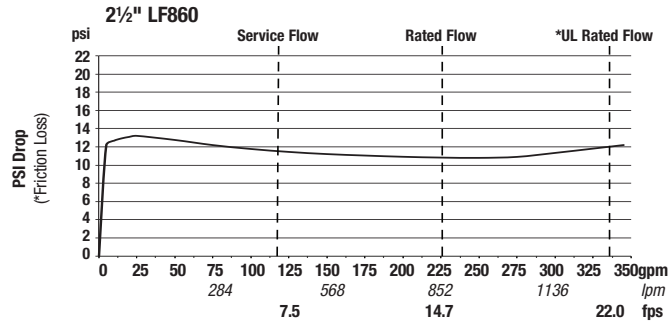

A WATTS Brand

USA: Tel: (800) 767-1234 • Fax: (800) 788-4491 • FEBCOonline.com
 Canada: Tel: (905) 332-4090 • Fax: (905) 332-7068 • FEBCOonline.ca
 Latin America: (52) 81-1001-8600 • Fax: (52) 81-8000-7091 • FEBCOonline.com

Application

Ideal for use where Lead-Free* valves are required. Designed for installation on potable water lines to protect against both backsiphonage and backpressure of contaminated water into the potable water supply. Assembly shall provide protection where a potential health hazard exists.



Standards Compliance

- ASSE® Listed 1013
- IAPMO® Listed
- CSA® Certified B64.4
- AWWA Compliant C511
- Approved by the Foundation for Cross Connection Control and Hydraulic Research at the University of Southern California
- Meets the requirements of NSF/ANSI 61*
*(0.25% MAX. WEIGHTED AVERAGE LEAD CONTENT)
- UL® Classified (less shut-off valves or with OS&Y valves)
- C-UL® Classified

Materials

Main valve body	Low Lead Cast Bronze ASTM B 584
Access covers	Low Lead Cast Bronze ASTM B 584
Fasteners	Stainless Steel, 300 Series
Elastomers	Silicone (FDA Approved) Buna Nitrile (FDA Approved)
Polymers	Noryl™
Springs	Stainless Steel, 300 series
Ball valve handles	Stainless Steel

Features

Sizes:	3/4", 1", 1-1/4", 1-1/2", 2"	175 PSI
Maximum working water pressure		180°F
Maximum working water temperature		350 PSI
Hydrostatic test pressure		ANSI B1.20.1
End connections	Threaded	

Relief Valve discharge port:	
3/4" - 1"	- 0.63 sq. in.
1 1/4" - 2"	- 1.19 sq. in.

Options

(Suffixes can be combined)

- with full port QT ball valves (standard)
- MS - with integral relief valve monitor switch
- S - with bronze "Y" type strainer
- BMS - with battery operated monitor switch
- FT - with integral male 45° flare SAE test fitting
- TCU - with test cocks up
- V - with union swivel elbows (3/4" & 1")
- SE - with street elbows (3/4" & 1")
- U - with union ball valves
- PF - with Z-Bite™ push fit connections* (1/2"-1" only)
- PR - with Z-Press™ press fit connections*

*Fittings ship in box with valve and must be threaded into valve by hand on site.

Accessories

- Air gap (Model AG)
- Repair kits (rubber only)
- Thermal expansion tank (Mdl. XT)
- Soft seated check valve (Model 40XL2)
- Shock arrester (Model 1250XL)
- QT-SET Quick Test Fitting Set
- Ball valve handle locks
- Test Cock Lock (Model TCL24)

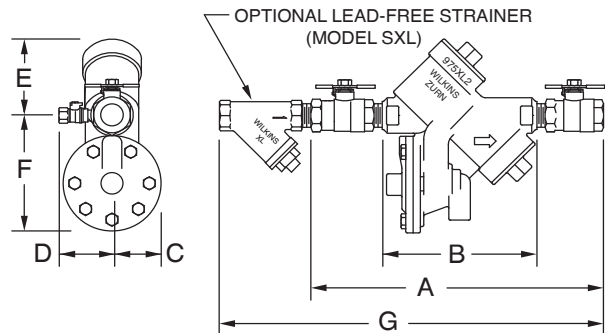

Dimensions & Weights (do not include pkg.)

MODEL SIZE	DIMENSIONS (approximate)																WITH BALL VALVES	
	A		B		C		D		E		F		G					
	in.	mm	in.	mm	in.	mm	in.	mm	in.	mm	in.	mm	in.	mm	lbs.	kg		
3/4	20	12	305	7 3/4	197	2 1/8	54	3	76	3 1/2	89	5	127	16 1/8	410	12	5.5	
1	25	13	330	7 3/4	197	2 1/8	54	3	76	3 1/2	89	5	127	17 3/8	441	14	6.4	
1 1/4	32	17	432	10 15/16	278	2 3/4	70	3 1/2	89	5	127	6 3/4	171	22 9/16	573	28	12.7	
1 1/2	40	17 3/8	441	10 15/16	278	2 3/4	70	3 1/2	89	5	127	6 3/4	171	24 1/16	611	28	12.7	
2	50	18 1/2	470	10 15/16	278	2 3/4	70	3 1/2	89	5	127	6 3/4	171	26 1/2	673	34	15.4	

MODEL 975XL2 3/4", 1", 1 1/4", 1 1/2" & 2" (STANDARD & METRIC)

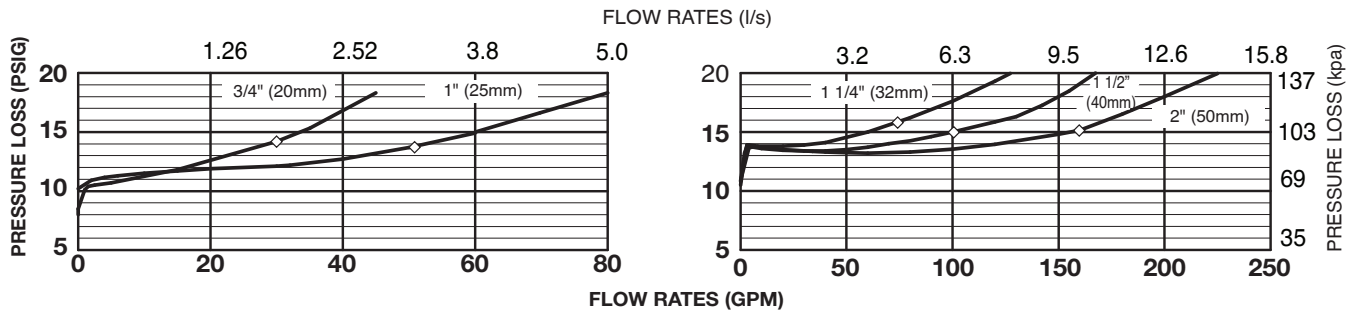

Typical Installation

Local codes shall govern installation requirements. To be installed in accordance with the manufacturers' instructions and the latest edition of the Uniform Plumbing Code. Unless otherwise specified, the assembly shall be mounted at a minimum of 12" (305mm) and a maximum of 30" (762mm) above adequate drains with sufficient side clearance for testing and maintenance. The installation shall be made so that no part of the unit can be submerged.

Capacity thru Schedule 40 Pipe				
Pipe size	5 ft/sec	7.5 ft/sec	10 ft/sec	15 ft/sec
1/8"	1	1	2	3
1/4"	2	2	3	5
3/8"	3	4	6	9
1/2"	5	7	9	14
3/4"	8	12	17	25
1"	13	20	27	40
1 1/4"	23	35	47	70
1 1/2"	32	48	63	95
2"	52	78	105	167

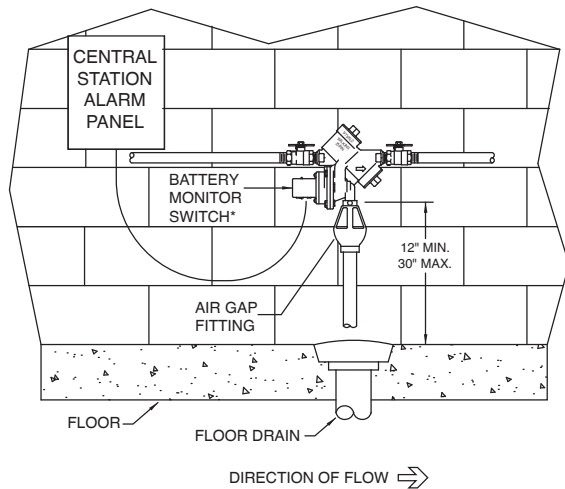

INDOOR INSTALLATION
(Shown w/optional BMS)

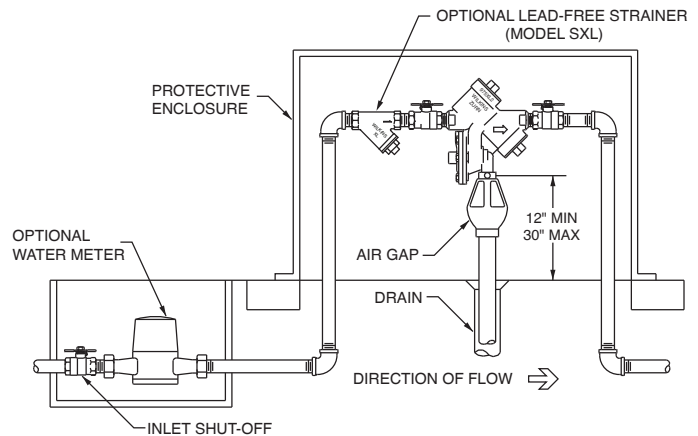

OUTDOOR INSTALLATION

Specifications

The Reduced Pressure Principle Backflow Preventer shall be certified to NSF/ANSI 61 shall be ASSE® Listed 1013, rated to 180°F, and supplied with full port ball valves. The main body and access covers shall be low lead bronze (ASTM B 584), the seat ring and all internal polymers shall be Noryl™ and the seat disc elastomers shall be silicone. The first and second checks shall be accessible for maintenance without removing the relief valve or the entire device from the line. If installed indoors, the installation shall be supplied with an air gap adapter and integral monitor switch. The Reduced Pressure Principle Backflow Preventer shall be a ZURN WILKINS Model 975XL2.

INSTALLATION DETAILS

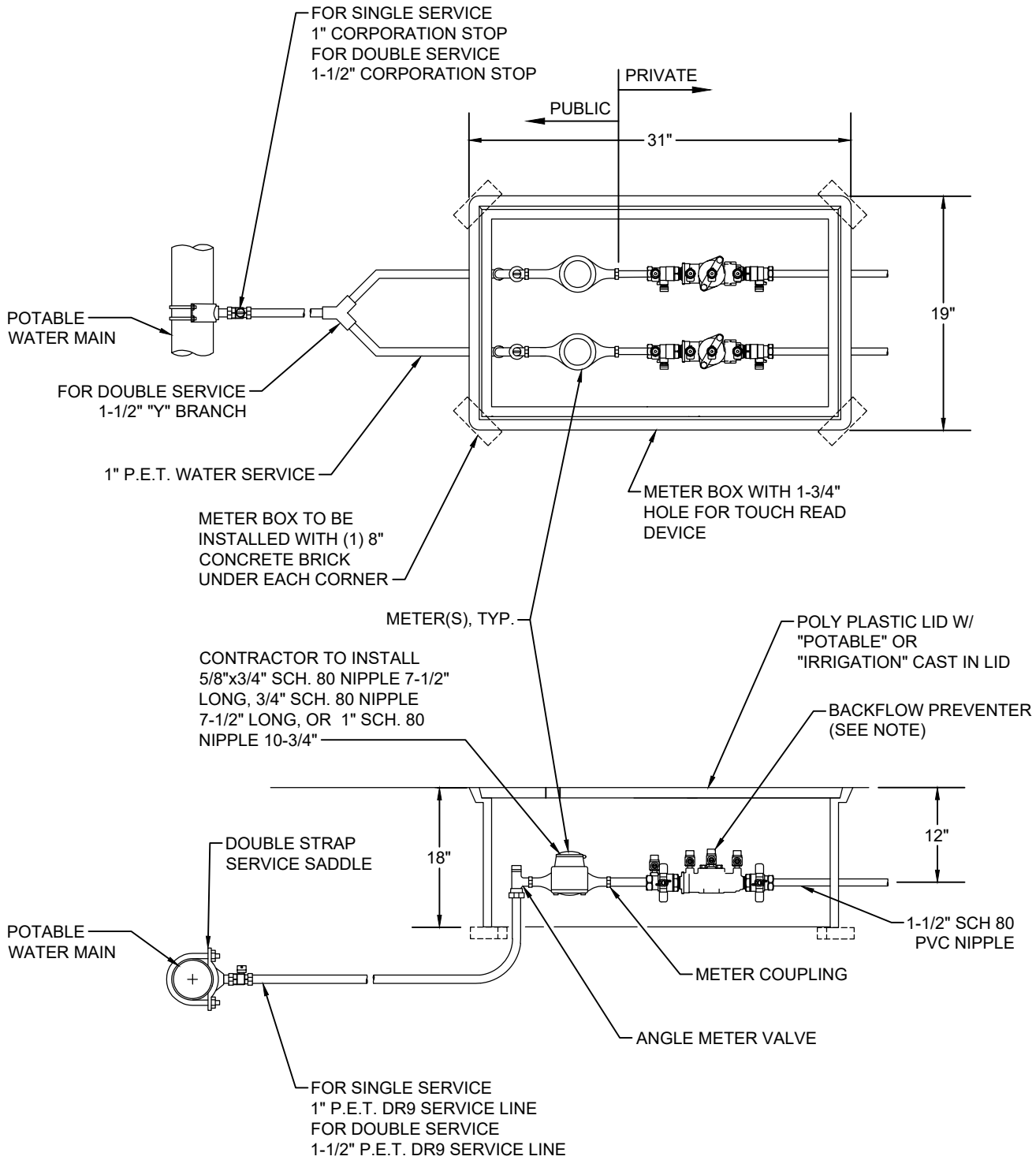

NOTES

1. REFER TO THE APPROPRIATE CROSS CONNECTION CONTROL MANUAL FOR ALL BACKFLOW PREVENTER REQUIREMENTS.

ISSUE DATE: 06-2022

NOT TO SCALE



**5/8", 3/4", AND 1" COMMERCIAL
POTABLE OR IRRIGATION
WATER METER ASSEMBLY**

W 10

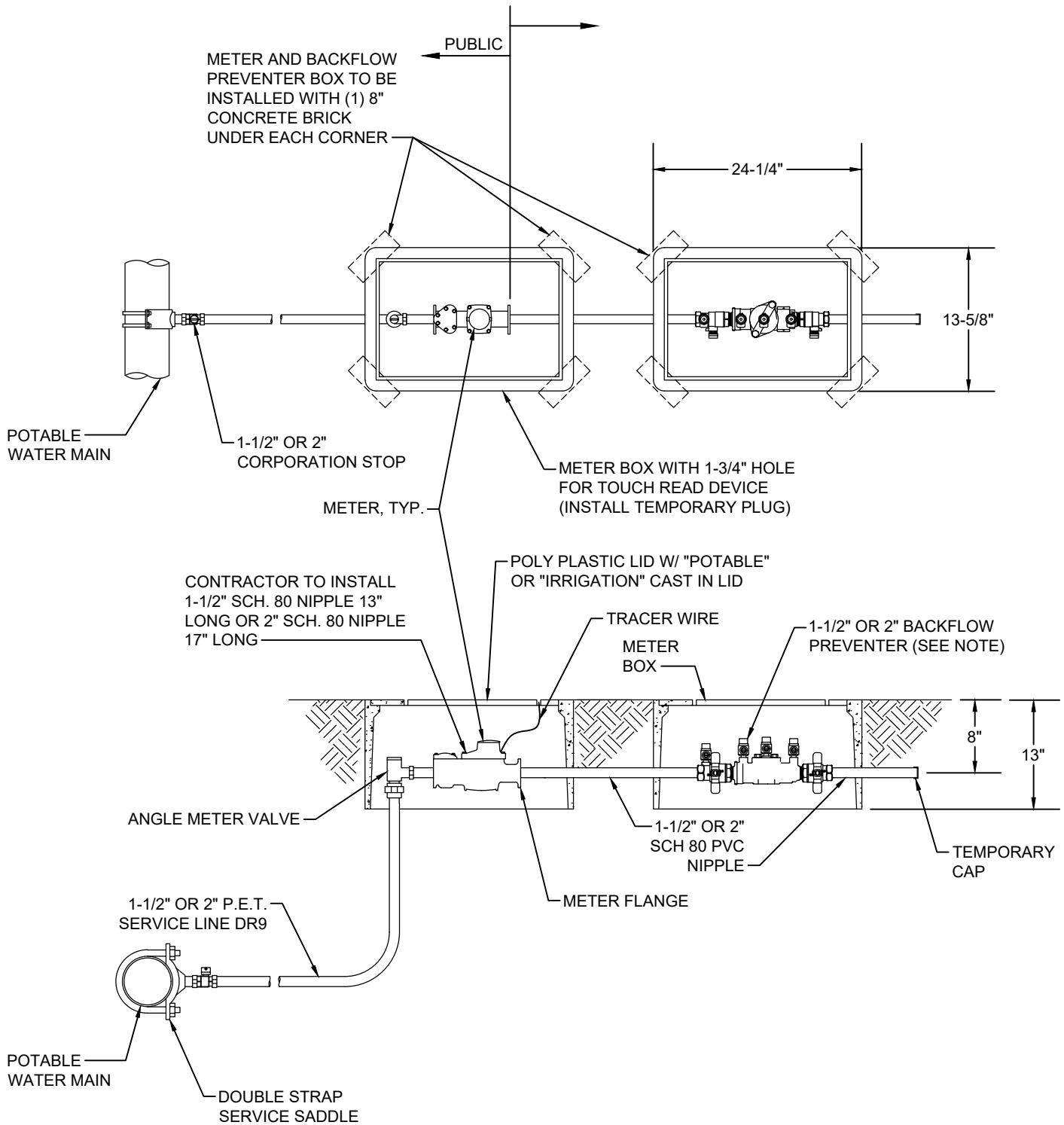

NOTES

1. REFER TO THE APPROPRIATE CROSS CONNECTION CONTROL MANUAL FOR ALL BACKFLOW PREVENTER REQUIREMENTS.

ISSUE DATE: 06-2022

NOT TO SCALE



**1-1/2" AND 2" COMMERCIAL
POTABLE OR IRRIGATION WATER
METER ASSEMBLY**

W 11

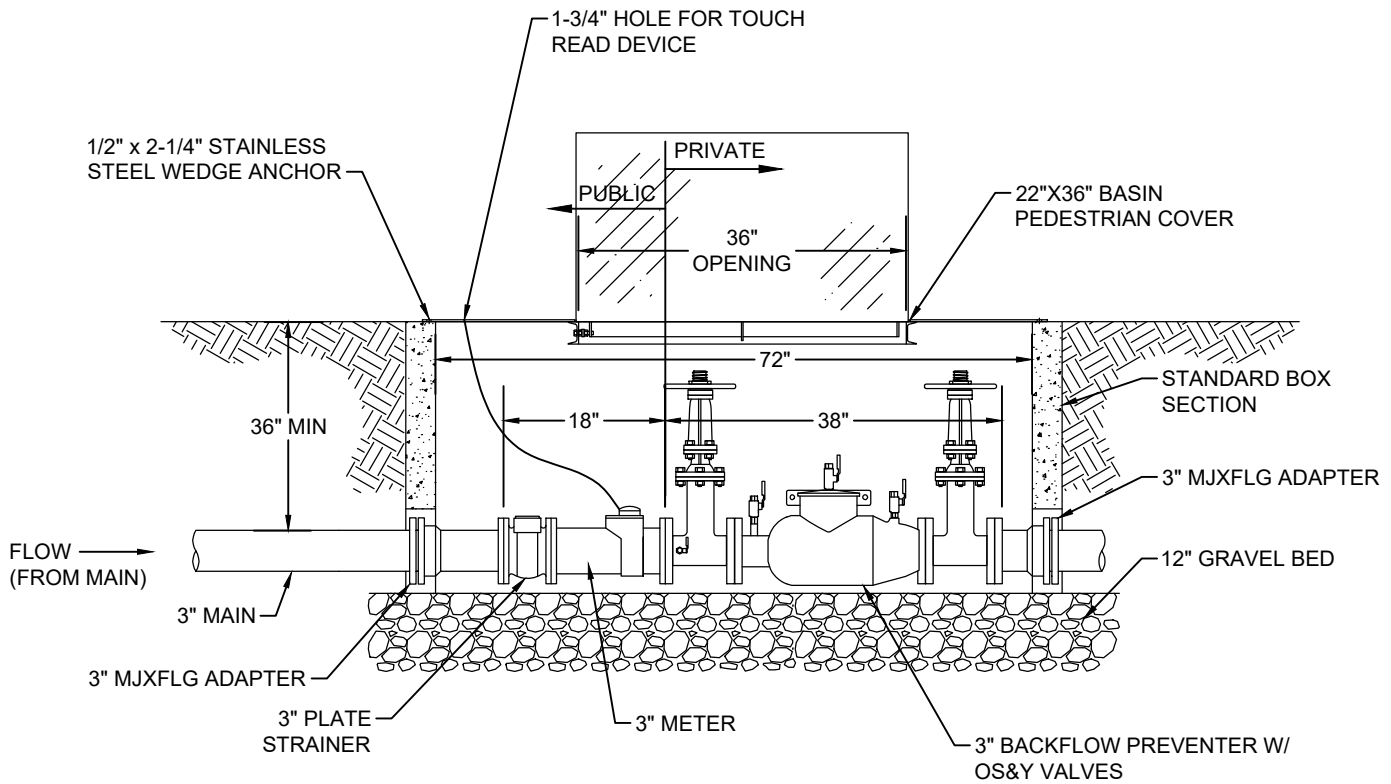

NOTES

1. REFER TO THE APPROPRIATE CROSS CONNECTION CONTROL MANUAL FOR ALL BACKFLOW PREVENTER REQUIREMENTS.

ISSUE DATE: 06-2022

NOT TO SCALE

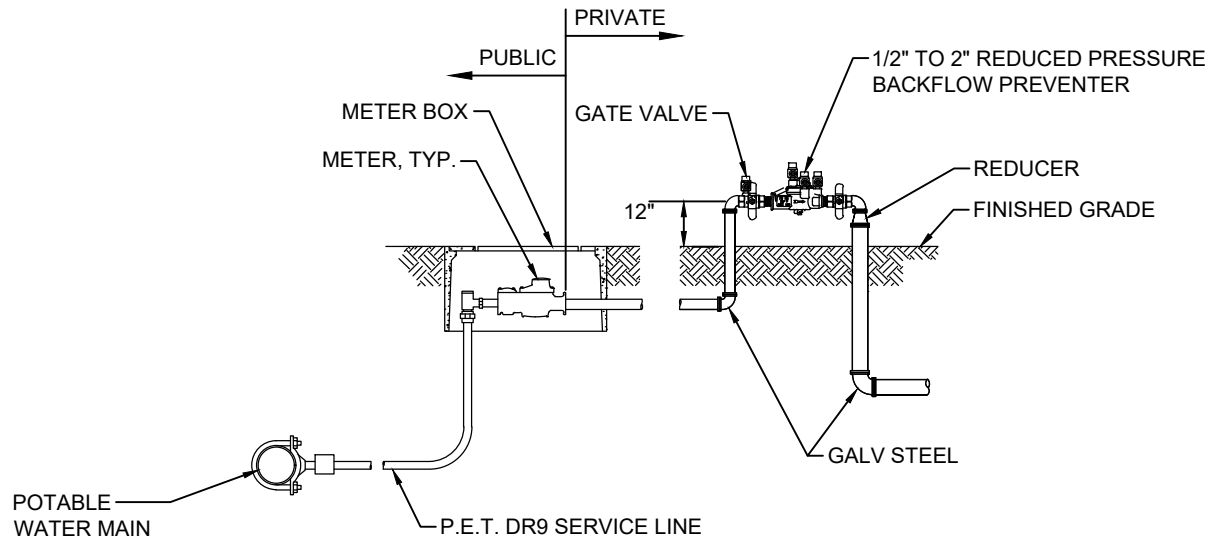
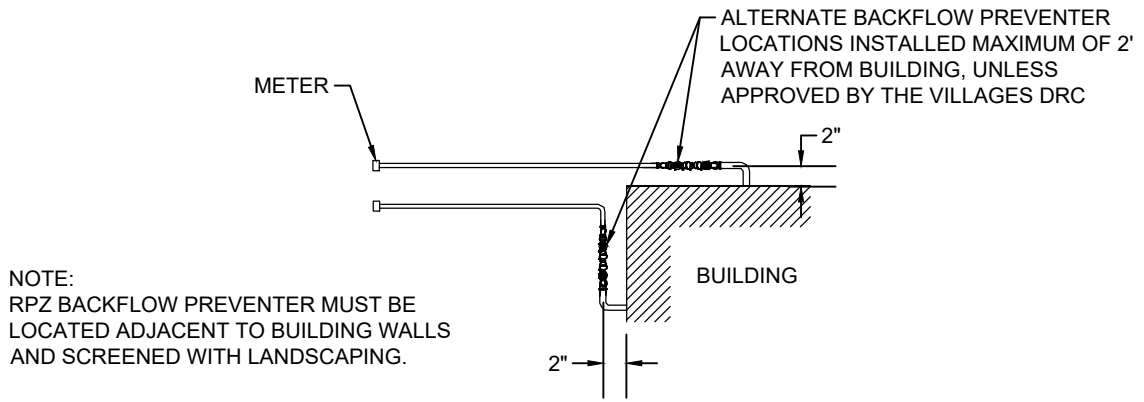

- NOTES:**
1. SEE APPROPRIATE ASSEMBLY DETAILS FOR ADDITIONAL INFORMATION.
 2. CONTRACTOR MUST SUBMIT BACKFLOW PREVENTION ASSEMBLY TEST REPORT PRIOR TO FINAL ACCEPTANCE OF SITE.
 3. REFER TO THE CROSS-CONNECTION CONTROL HANDBOOK FOR APPROPRIATE JURISDICTIONS.

NOTES

1. REFER TO THE APPROPRIATE CROSS CONNECTION CONTROL MANUAL FOR ALL BACKFLOW PREVENTER REQUIREMENTS.

ISSUE DATE: 06-2022

NOT TO SCALE



**HIGH RISK COMMERCIAL
BACKFLOW PREVENTER
ASSEMBLY**

W 17

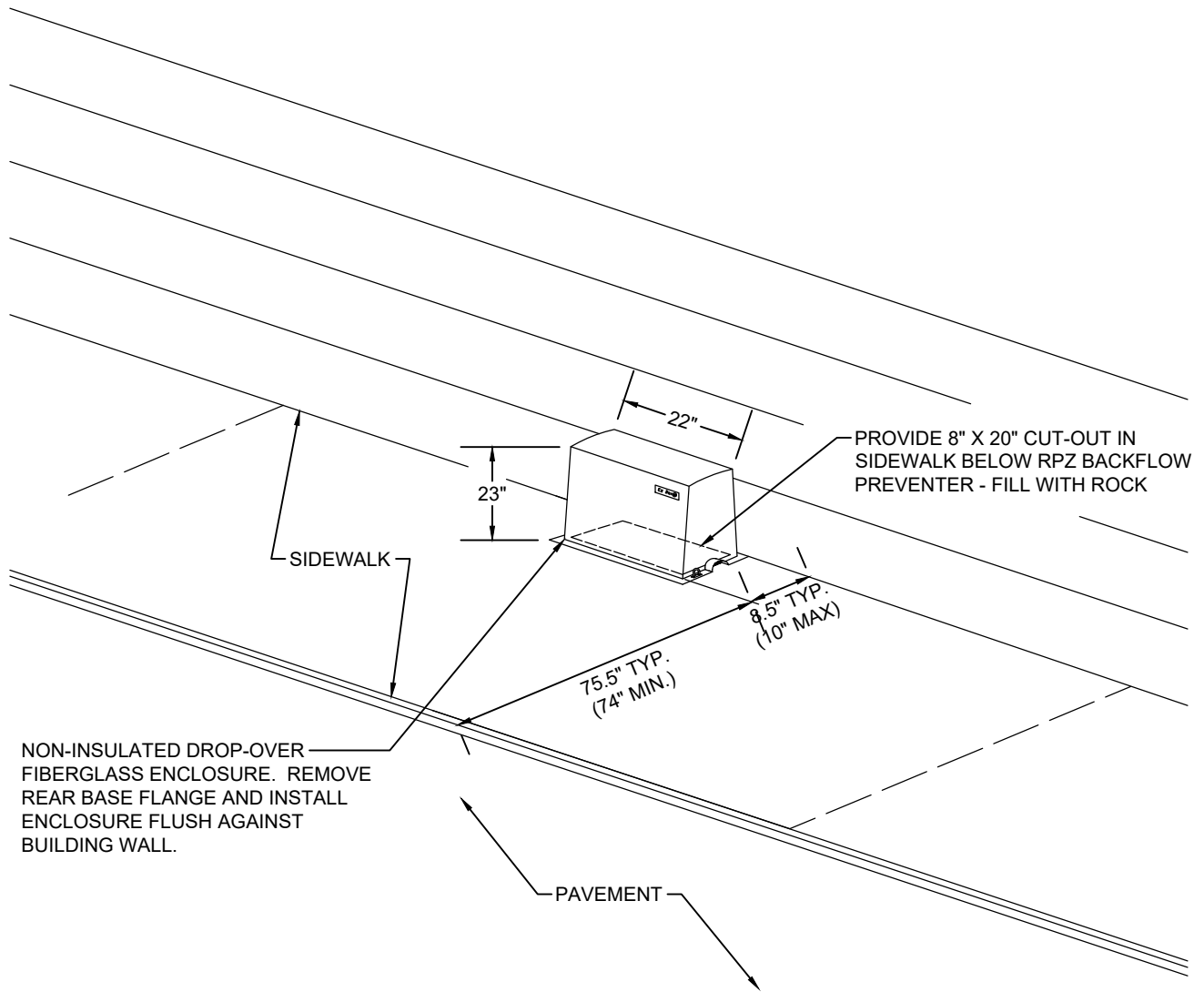

NON-INSULATED DROP-OVER FIBERGLASS ENCLOSURE. REMOVE REAR BASE FLANGE AND INSTALL ENCLOSURE FLUSH AGAINST BUILDING WALL.

PROVIDE 8" X 20" CUT-OUT IN SIDEWALK BELOW RPZ BACKFLOW PREVENTER - FILL WITH ROCK

NOTES

- ENCLOSURE REQUIRED ONLY IF A RPZ BACKFLOW PREVENTER MUST BE INSTALLED ABOVE GRADE IN NON-LANDSCAPED AREAS.

ISSUE DATE: 06-2022

NOT TO SCALE



BACKFLOW PREVENTER ASSEMBLY ENCLOSURE

W 17-2